



Installation Operation Maintenance

Cond. Unit TRCE - 5 to 15 TR (Centrifugal Fan)

Cond. Unit TRAE - 5 to 30 TR (Axial Fan)

Cond. Unit CRCB - 5 to 15 TR

Cond. Unit CRCE - 5 to 15 TR

Split System

50/60Hz



Models:

TRAE050 1C	TRAE200 1C	TRCE050 1C	CRCB050 1C	CRCE050 1C
TRAE075 1C	TRAE200 2C	TRCE075 1C	CRCB075 1C	CRCE075 1C
TRAE100 1C	TRAE250 1C	TRCE100 1C	CRCB100 1C	CRCE100 1C
TRAE100 2C	TRAE250 2C	TRCE100 2C	CRCB100 2C	CRCE100 2C
TRAE125 2C	TRAE300 2C	TRCE125 2C	CRCB125 1C	CRCE125 1C
TRAE150 1C		TRCE150 1C	CRCB125 2C	CRCE125 2C
TRAE150 2C		TRCE150 2C	CRCB150 1C	CRCE150 1C
			CRCB150 2C	CRCE150 2C

SAFETYWARNING

Only qualified personnel should install and service the equipment. The installation, starting up, and servicing of heating, ventilating, and air-conditioning equipment can be hazardous and requires specific knowledge and training. Improperly installed, adjusted or altered equipment by an unqualified person could result in death or serious injury. When working on the equipment, observe all precautions in the literature and on the tags, stickers, and labels that are attached to the equipment.

Important Notice

Literature History

The new manual describes installation, operation and maintenance for TRAE and TRCE condensing units, which are part of Trane split system Solution Plus. For further information on Solution Plus installation, operation and maintenance, refer to literature SSSVN01A-PT, which includes detailed information about the Solution Plus set, which includes evaporating and condensing units.

IMPORTANT:

Dimensional measuring units on this catalog are on milimitres (mm). (Except for those locally referencied).

Refrigerant Emission Control

Trane-recommended service and operation procedures must be followed in order to allow gas conservation and gas emission reduction, with a special attention to:

The refrigerant used in any type of air conditioning equipment should be recovered and/or recycled for reuse, reclaimed or completely destroyed whenever it is removed from the equipment. **Never release it into the atmosphere.**

Before starting recovery through any method, always consider the possibility of recycling or reprocessing the transferred refrigerant.

Issues involving recovered refrigerants and acceptable qualities are described in norm ARI 700.

Use safe and approved cylinders. Follow all applicable transport and safety norms when transporting refrigerant containers.

To minimize emissions during refrigerant gas transfer, use recycling equipment. Always use methods that produce the lowest possible vacuum while recovering and condensing the refrigerant inside the cylinder.

Important:

As Trane do Brasil has the policy of continually enhancing its products, it reserves the right to change specifications and drawings without prior notice. Only technicians accredited and/or authorized by Trane should install and maintain equipment specified in this manual. If any procedure contained in this manual is ignored and/or not adopted, product warranty may be void.

Contents

I-General Data	4
II-Unit Inspection	6
III-Transport and Movement	7
IV-Refrigeration Piping (Interconnection)	8
V-Maintenance	12
VI-Operational and Electric Features	14
VII-Wiring Diagram	15
VIII-Dimensional Data	82
Application Considerations TRAE/TRCE	93
IX-Standard Conversion Table	94



I-General Data

TRAE/TRCE

Tab I-01 - General Data - Condensing Units TRAE - 050 to 300

Model	50	75	100	125	150	200	250	300
Nominal Cap.	Ton 5	7,5	10	12,5	15	20	25	30
Dimensions								
Width	mm 920	930	1140	1350	1590	1067	1067	1850
Depth	mm 420	620	800	800	800	1096	1096	1060
Height	mm 818	920	1021	1275	1275	1452	1452	1600
Compressor								
Type	Scroll	Scroll	Scroll	Scroll	Scroll	Scroll	Scroll	Scroll
Qty.	Ton 1	1	1 2	2	1 2	1 2	1or 2	2
Condensing Coil								
Rows	2	2	2 2	2	2	2	2 2	3
FPF (Fins per foot)	228	216	216 216	216	216	204	204	144
Fin Side Area	m ² 0,8	1,01	1,67 1,67	2,24	2,24	2,97	3,33	4,5
Condensing Fan								
Quantity	1	1	1 1	1	2	1	1	2
Propeller diameter	mm 22"	26"	30" 30"	30"	26"	35"	35"	30"
Air Flow	m ³ /h 7234	9180	11900 11900	15300	18360	23800	30600	32300
Pipe Diameters								
Number of Circuits	1	1	1 2	2	1 2	1 2	1 2	2
Liquid Line	in. 1/2"	1/2"	5/8" 1/2"	1/2"	7/8" 1/2"	7/8" 5/8"	11/8" 5/8"	7/8"
Suction Line	in. 7/8"	11/8"	13/8" 7/8"	C1: 11/8" C2: 7/8"	15/8" 11/8"	15/8" 13/8"	2 1/8" 13/8"	15/8"
Equipment Weight	kg 108	127	198 196	227	335 275	355 359	360 368	610

Tab. I-02 - General Data - Condensing Units TRCE 050 to 150

Model	050	075	100	125	150
Nominal Cap.	Ton 5	7,5	10	12,5	15
Dimensions					
Width	mm 993	1217	1491	1712	1712
Depth	mm 560	560	560	560	560
Height	mm 1393	1494	1545	1620	1849
Compressor					
Type	Scroll	Scroll	Scroll	Scroll	Scroll
Qty/Ton	Ton 1/5	1/7,5	1/10 2/5	C1: 1/7,5 C2: 1/5	1/15 2/7,5
Condensing Coil					
Rows	1	1	1	1	1
FPF (Fin per Feet)	ft 276	276	276	276	276
Fin Side Area	m ² 0,55	0,83	0,99	1,39	1,72
Quantity	1	1	1	1	1
Condensing Fan					
Motor	CV 1,5	3	4	4	5
N° Fase	3	3	3	3	3
Nominal Power	kW 1,22	2,23	2 x 2,93	2 x 2,93	2 x 3,54
Equipment Weight	kg 184	210	305 310	352	400 400

Note:
 (1) RLA= Rated Amps - 220V/60 Hz.
 (2) FLA= Full Load Amps - 220V/60 HZ
 (3) Voltage variation: +/- 10%

General Data

CRCB/CRCE

Tab. I-03 - General Data - Condensing Unit CRCE 050 to 150 for use w/ SIVE.

Model		050	075	100	125	150			
Nominal Cap. ⁽¹⁾	Ton	5	7,5	10	12,5	15			
Length	mm	993	1217	1491	1712	1712			
Depth	mm	560	560	560	560	560			
Height	mm	1393	1494	1545	1620	1849			
Coil									
Rows		1	1	1	1	1			
FPF (Fins per foot)	ft	276	276	276	276	276			
Finned Face Area	m ²	0,55	0,83	0,99	1,39	1,72			
Fan Motor									
Quantity		1	1	1	1	1			
Motor	HP	1,5	3	4	4	5			
Nº Phase		3	3	3	3	3			
Nominal Power	kW	1,17	2,18	2,83	2,83	3,46			
RLA ⁽³⁾	A	3,85	7,94	9,28	9,28	11,20			
FLA ⁽⁴⁾	A	4,81	9,93	11,60	11,60	14,00			
LRA ⁽⁵⁾	A	22,42	77,45	87,00	87,00	106,40			
Rotation/Nº Poles	RPM	1700 / 4	1710 / 4	1720 / 4	1720 / 4	1730 / 4			
Air Flow	m ³ /h	5500	8250	9950	13770	15750			
Pipe Diameters									
Number of Circuits		1	1	1	2	1	2	1	2
Liquid Line	in	1/2"	1/2"	5/8"	1/2"	5/8"	1/2"	7/8"	1/2"
Suction Line	in	5/8"	3/4"	7/8"	5/8"	1 1/8"	C1: 3/4" C2: 5/8"	1 1/8"	3/4"
Equipment Weight(3)	kg	148	170	233	236	276	278	315	320

Tab. I-04 - General Data - Remote Condensing Unit CRCB 100 to 150 for use w/ SIVE

Remote (w/ SIVE) and Air-Cooled Condenser CRCB						
Model		CRCB050	CRCB075	CRCB100	CRCB125	CRCB150
Nominal Cap. ⁽¹⁾	TR	5	7,5	10	12,5	15
Coil						
Rows		1	1	1	1	1
FPF (Fins per foot)		276	276	276	276	276
Finned type		Aletas de aluminio corrugadas				
Finned face area	m ²	0,54	0,83	0,99	1,38	1,72
Fan						
Quantity		1	1	2	2	2
Type		Centrifugo				
Diam. x Length	mm	321 x 321	321 x 321	270 x 270	321 x 321	321 x 321
Motor	CV	1	3	3	4	5
Air Flow	m ³ /h	5450	8315	9935	13930	17320
Dimensions - Remote Condenser- CRCB						
Length	mm	987	1241	1341	1646	1646
Depth	mm	631	631	631	714	714
Height	mm	890	890	941	1018	1247
Net Weight	kg	93	124	139	180	212

Note:
 (1) Data according to conditions in standard ARI 210.
 (2) Equipment weight refers to the Standard machine.
 (3) RLA = Rated Load Amps (A) - 220V/60hz;
 (4) FLA = Full Load Amps (A) - 220V/60hz;
 (5) LRA = Locked Rotor Amps (A) - 220V/60hz.

II-Unit Inspection

Unit Inspection

Upon unit arrival at the installation location, proceed as follows:

- Make sure that the nameplate data matches Sales Order and delivery note data (including electrical ratings);
- Make sure the local power supply complies with nameplate ratings;
- Carefully inspect the unit looking for any sign of damage during transport. In case of any damage or lack of material, notify the carrier immediately. Specify the damage class and amplitude in the shipping/delivery note, before signing it;
- Report damages and actions to be taken for appropriate repair to Trane do Brasil and/or the Contractor. The unit should only be repaired after damage inspection.

Storage

At delivery, if the unit cannot be placed in its permanent location, store it in a safe and weatherproof location and/or one that is not affected by other damage originators. Undue equipment storage and movement will result in void equipment warranty.

Instructions for proper installation

For proper installation, consider the following items before putting the unit into place:

- The engine room should have coherent lightning for service and/or maintenance.
- The unit floor or basis must be leveled, solid and sufficiently resistant to support the weight of the unit and its accessories. Level or repair the floor where the unit is to be installed before putting it into place.
- Provide rubber grommets or vibration insulators for the units.
- Perform the hydraulic installation required to drain water from the condensate drip pan.
- Provide the recommended minimum clearances for routine maintenance and services (see page 22 of this manual).
- Consider the same clearances for multiple units together or condensing units.
- Perform the electric installation. Electric connection inlets are provided on both sides of the units.
- Provide enough clearances for accessing the piping and removing the covers.
- Power supply must comply with Norm NBR 5410, local and/or NEC codes.
- The contractor should provide and install the refrigerating piping - liquid line and suction line, in order to interconnect EU evaporating units and CU condensing units.

General Safety

TRAE and TRCE condensing units are designed for safe and reliable operation, whenever units are operated accordingly to safety norms.

The system operates with electric components, mechanical components, gas and water pressures, etc., which can result in damages to people and equipment, if required safety norms are not observed.

Thus, only installers who are accredited and/or authorized by Trane do Brasil should perform installation, startup and maintenance in this equipment.

Follow all working safety norms and warnings in labels attached to the units. Always use appropriate equipment and tools.

Danger Identification



WARNING!

Warning are provided at appropriate intervals and places in this manual to indicate to operators and service personnel of potentially hazardous situations which **MAY** result in serious personal injuries or damage to the equipment, if safety norms are not observed.



CAUTION!

Caution are provided at appropriate intervals and places in this manual to indicate to operators and service personnel of potentially hazardous situations that may result in damages to equipment and/or to the environment.

III-Transport and Movement

Fig. III-01 - Instructions for transport and movement.

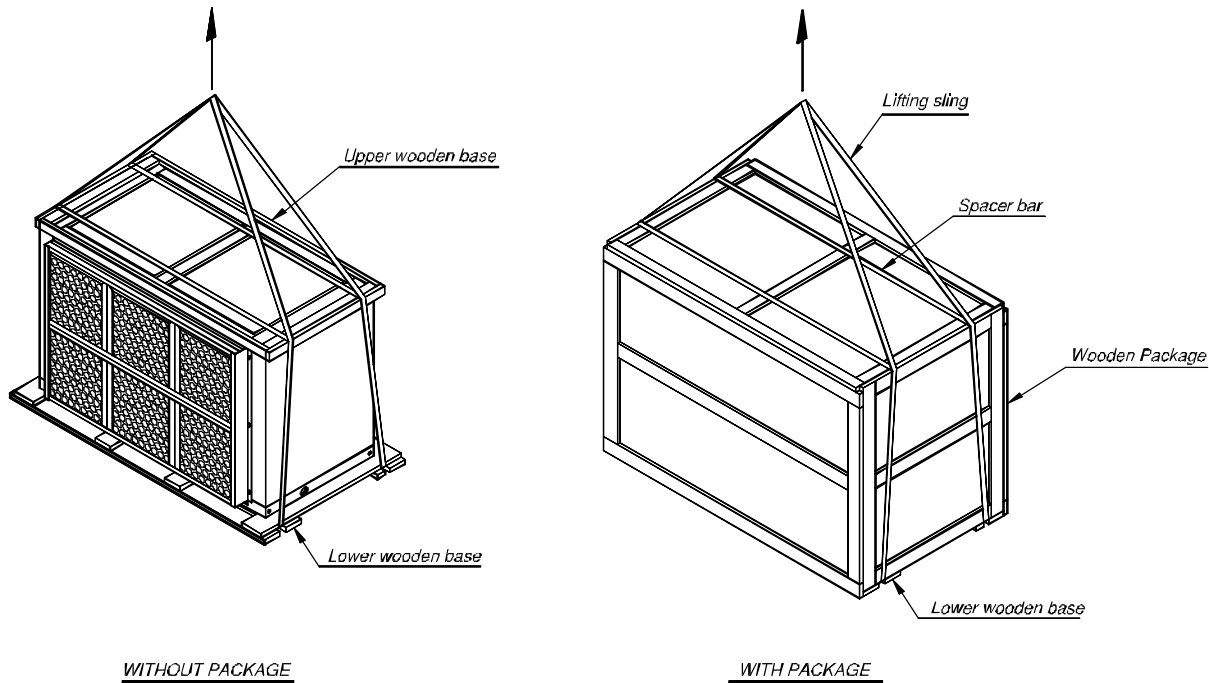

WARNING!
 To avoid death or unit damage, equipment lifting capacity should exceed the unit weight and include an appropriate safety factor.

WARNING!
 Each cable, belt or chain used to lift the unit should be able to support the total unit weight.

Instructions for handling and movement

For unit transport and movement, follow these instructions:

1. Check the actual equipment weight in the manual or on the nameplate.
2. For all units, place the cables or lifting chains under the wooden skid. Other lifting operations may cause equipment damages and serious personal injuries.
3. Avoid contact between steel cables, riggings or chains and the conditioner, preventing damages or accidents. Use adequate spacer bars, as shown in the drawing.
4. Do not remove module package until its placement in the permanent installation location. Be careful when moving the equipment.
5. During transport, do not swing the equipment more than 15° (fifteen degrees) in relation to its vertical position.
6. Always perform a lifting test to determine the exact stability and balance of the unit, before lifting it into the installation place.
7. For horizontal movement, use rollers of equal diameter under the wooden base.

IV-Refrigeration Piping (Interconnection)

TRAE/TRCE

Condenser Unit

To install remote condenser units, the following precautions must be taken:

- The condenser unit must be placed in a well ventilated area and comply with the clearance recommendations.
- The length of interconnection line between the evaporator unit and the condenser unit should be as short as possible;
- Do not reduce the line gauge;
- Avoid curves in the interconnection lines;
- Do not install the condenser unit in shafts or tunnels;
- The CU must be as close as possible to a horizontal line.
- Pipes must be soldered with silver or foscofer.
- Special care should be taken not to cause any type of obstruction in the pipes when soldering the lines. The interconnection pipes must not be dented. All soldering must be effected with nitrogen circulating inside the pipes to avoid carbonization
- When the interconnection lines are ready, pressure test the system at 200 psig to check for leaks.
- Evacuate the whole system - interconnection lines, evaporator and condenser units.
- Carry out refrigerant charge.

Instructions for Fixing the Expansion Valve Thermostatic Bulb

- In the suction line, as closest as possible to the evaporator output.
- Before external equalization, in an horizontal line run.

- The copper tube must be completely clean.
- At the 12h position for pipes smaller than 7/8", and 4h or 8h position for 7/8" or larger pipes.
- Then insulate the pipes using thermal sheets.

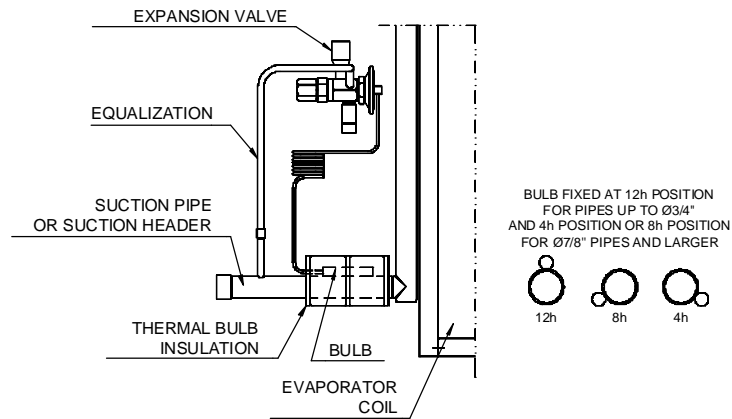

Tab. IV-01 - Tubing and connection gauges recommended by circuit

Line (Ton)	Connection gauge (in.)				Equivalent Tubing Length							
	Coil Mod.		TRAE/TRCE		6 m		6 to 12 m		12 to 23 m		23 to 46 m	
	Liq	Suct	Liq	Suct	Liq	Suct	Liq	Suct	Liq	Suct	Liq	Suct
5	1/2"	7/8"	1/2"	7/8"	1/2"	7/8"	1/2"	7/8"	1/2"	1 1/8"	5/8"	1 1/8"
7.5	1/2"	1 1/8"	1/2"	1 1/8"	1/2"	1 1/8"	1/2"	1 1/8"	5/8"	1 1/8"	3/4"	1 3/8"
10	5/8"	1 3/8"	5/8"	1 3/8"	5/8"	1 3/8"	5/8"	1 3/8"	5/8"	1 3/8"	3/4"	1 5/8"
12.5	5/8"	1 3/8"	5/8"	1 3/8"	5/8"	1 3/8"	5/8"	1 3/8"	3/4"	1 5/8"	7/8"	1 5/8"
16	7/8"	1 5/8"	7/8"	1 5/8"	3/4"	1 5/8"	3/4"	1 5/8"	3/4"	1 5/8"	7/8"	2 1/8"
20	7/8"	1 5/8"	1 1/8"	1 5/8"	7/8"	1 5/8"	7/8"	1 5/8"	7/8"	1 5/8"	7/8"	2 1/8"
25	1 1/8"	2 1/8"	1 1/8"	2 1/8"	1 1/8"	2 1/8"	1 1/8"	2 1/8"	1 1/8"	2 1/8"	1 1/8"	2 5/8"

Note: For equivalent lengths above the values indicated, please contact Trane or an authorized installer.

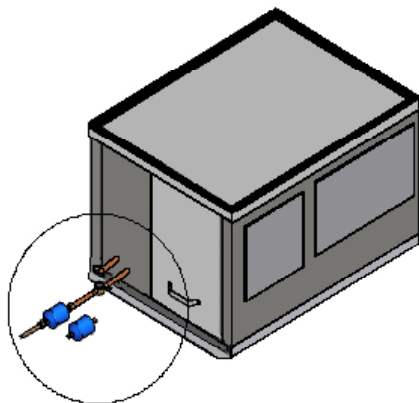

MOUNTING DIAGRAM
DRIER FILTER

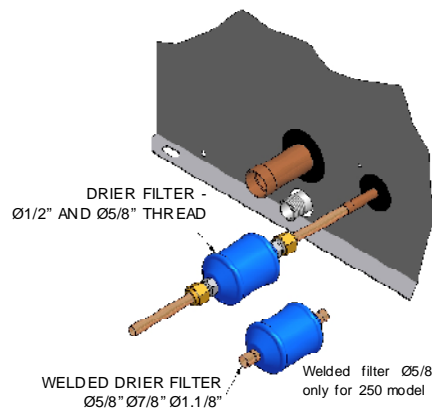

MOUNTING DIAGRAM
DRIER FILTER AND LIQUID SIGHT GLASS

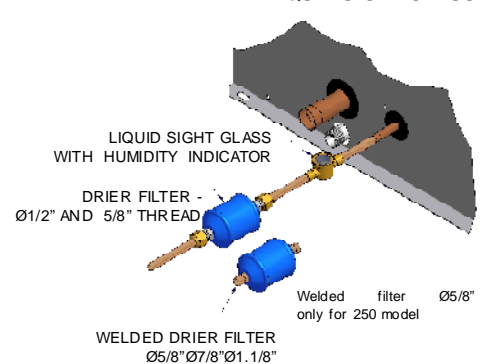

Refrigerating Tubing - Interconnection

TRAE/TRCE

Refrigerant Piping

Units should be interconnected with copper pipes.

Connection gauges of evaporating units and remote condensing units TRAE or TRCE, and suction and liquid piping gauges recommended for interconnecting both are indicated on Table 03.

The corresponding lengths already include losses generated by valves, curves, elbows, reductions, etc.

Maximum distance (recommended)

distance between units: **46 m.**

difference in levels between units: **18 m.**

For distances higher than the recommended value, please contact **Trane do Brasil.**

Evaporating Unit above the Condensing Unit

- Build a 20 cm inverted syphon in the suction line at the evaporating unit outlet, after the regular oil accumulation syphon.

- Horizontal sections in the suction line should be inclined by 45 mm at every 10 m of line towards condensing unit.

Condensing Unit above the Evaporating Unit

- Build a 10 cm syphon at rising and a syphon at every 7.5 m of vertical line.

- Horizontal sections in the suction line should be inclined by 45 mm at every 10 m of line towards condensing unit.

Fig. IV-01 - Assembly Evaporating Unit over Condensing Unit.

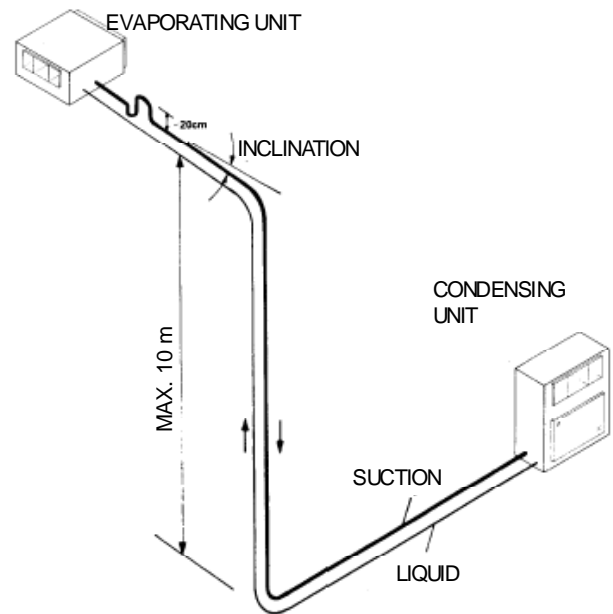
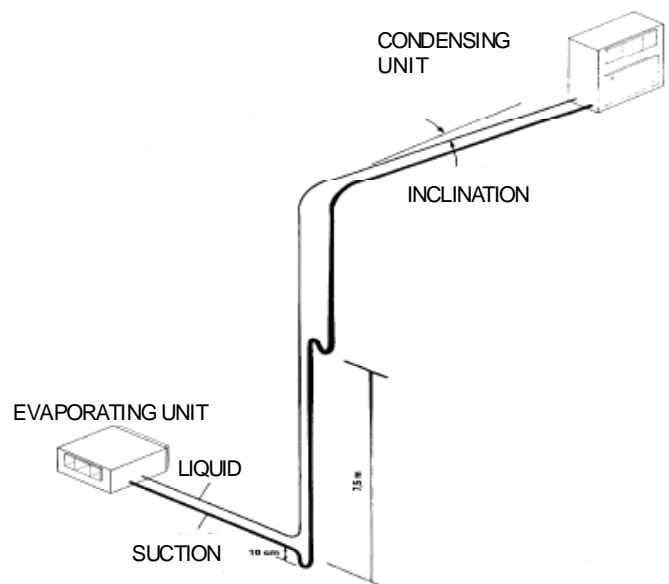

Fig. IV-02 - Assembly Condensing Unit over Evaporating Unit.



Refrigerating Tubing - Interconnection

TRAE/TRCE

Condensing Unit at the same level as Evaporating Unit (fig. on the right)

- Build a 20 cm inverted syphon in the suction line at the evaporating unit outlet, after the regular oil accumulation syphon.
- Horizontal sections in the suction line should be inclined by 45 mm at every 10 m of line towards condensing unit.

Nominal Load of Refrigerant R-407

The nominal load of refrigerant R-407 and oil for the units is indicated in Table 04.

The refrigerant in the piping that should be added is not considered in these loads. When the distance between the evaporating unit and the condensing unit is **more than 5 meters**, it is necessary to complement the refrigerant load. The calculation is based on Table 05.

The refrigerant load will only be correct when superheat and subcooling range is 8°C to 12°C and 5°C to 10°C, respectively. See Table 07 on page 09 of this manual.

Nominal Oil Load

In installations where the actual length is higher than 20 m, add 0.10 liters of oil for each kg of refrigerant added due to tubing.

Note: The oil used and the Trane Oil 48 (R-407 - Synthetic).

Fig.IV-03 - Assembly diagram for EU at the same level as CU

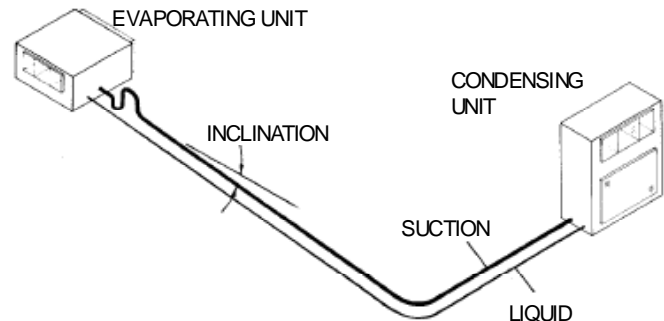

Tab.IV-04 - Nominal load of refrigerant R-407 and oil load.

Model (TON)	Refrigerant R-407C (kg)	Oil (liters) Initial load
5	3,52	1,66
7,5	4	1,77
10	3,52 + 3,52	1,66 + 1,66
12,5	5,40 + 3,52	1,77 + 1,66
15	5,40 + 5,40	1,77 + 1,77
20	8,32 + 8,32	3,80 + 3,80
25	10,30 + 8,32	6,20 + 3,80
30	10,30 + 10,30	6,20 + 6,20
35	12,30 + 10,30	8,00 + 6,20
40	12,30 + 12,30	8,00 + 8,00
50	15,30 + 15,30	8,00 + 8,00

Tab. IV-05 - Additional load of refrigerant R-407.

Diameter	Suction Line (kg/m)	Liquid Line (kg/m)
1/2"	0.001	0.11
5/8"	0.004	0.18
3/4"	0.006	0.26
7/8"	0.007	0.37
1 1/8"	0.011	0.63
1 3/8"	0.019	0.96
1 5/8"	0.028	-/-
2 1/8"	0.05	-/-
2 5/8"	0.076	-/-

Refrigerating Tubing - Interconnection

CRCB/CRCE

Recommendations for refrigerating and accessories installation

Condenser Unit above Evaporator Unit

a. Put a trap in the riser base of the discharge line. If the vertical riser exceeds 7,5 m, put an additional trap in each 7,5 m. Install it at the middle of the piping. Make an inverse trap next to the condenser, according to figure above.

b. In the horizontal sections of the discharge line, put a 45 mm inclination in the direction of the flow of refrigerant each 10 meters.

Evaporator Unit above Condenser Unit and at the Same Level

In these cases, it is not necessary to make traps; it is enough to put a 45 mm inclination in the horizontal sections in the direction of the flow, each 10 m.

Figure IV-06 - Recommendations For Refrigerating Installation. Condenser Unit above Evaporator Unit

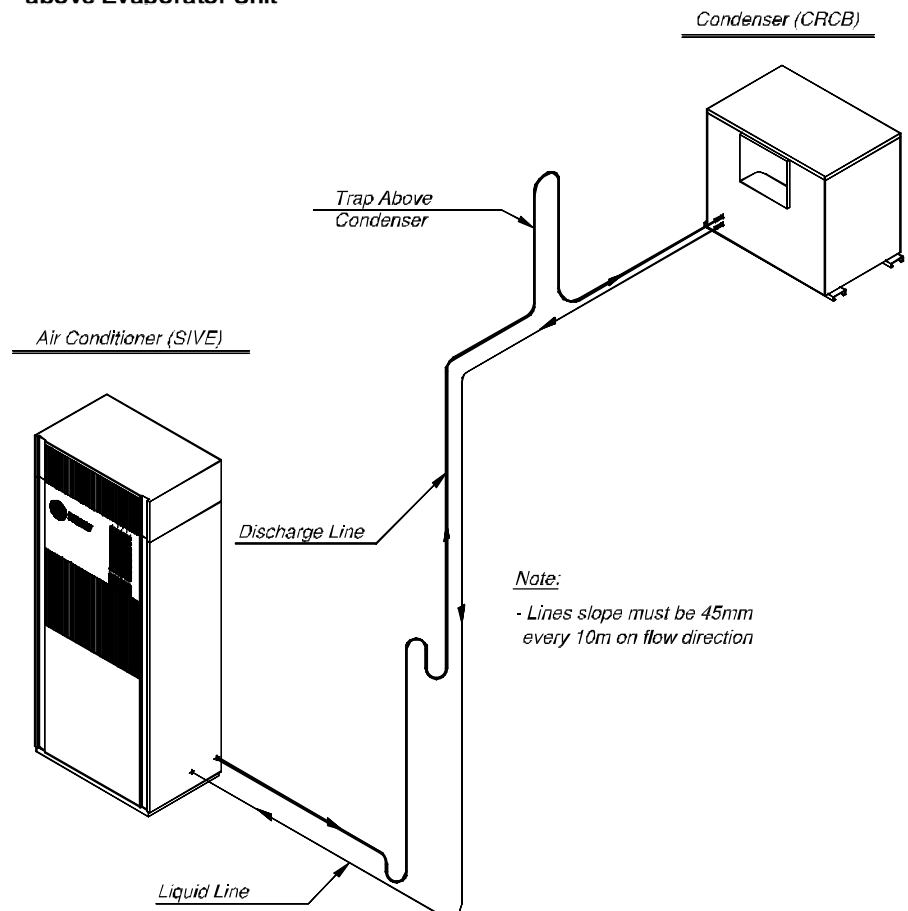



V-Periodic Preventive Maintenance

Preventive Maintenance

IMPORTANT

Perform all inspections and maintenance services at recommended intervals. This will extend the equipment life and reduce the possibility of equipment failure.

Operational conditions of this unit should be logged monthly. The operational data sheet may be an invaluable tool for technical support personnel during diagnosis. By noting operational condition trends, the operator can often foresee and avoid problems before they become serious. If the unit is not operating properly, please refer to the irregularity analysis section, at the end of this manual.

Weekly Maintenance

After the equipment has been running for approximately 30 minutes and the system is stable, check the operation conditions and follow these checking procedures:

- Clean permanent air filters more often, according to the installation site.

Monthly Maintenance

- Clean permanent air filters. Replace throwaway filters.
- Check fan belts for tension, alignment and wear.
- Clean the fan volutes.
- Tight again all terminal bolts.
- Clean the evaporator pan, the hose and the condensed water drain.

- Check the liquid line sight glass. Test against leakages and repair them, if required.

If operational conditions and liquid sight glass indicate lack of gas, measure the system superheat and subcooling. Please refer to "System Superheat" and "System Subcooling" sections.

If operational conditions indicate overcharge, slowly remove (to minimize oil loss) refrigerant through the service Schrader valve of the liquid line.

Inspect the system to detect abnormal conditions. Use the log sheet to register unit conditions. A comprehensive log sheet is an invaluable tool for technical support personnel.

Quarterly Maintenance

Perform all monthly maintenance services.

Check sheave and bearing fastening bolts. Adjust them, if necessary.

Clean the condenser more often, according to the installation site.

Clean the evaporator more often, according to the installation site.

Check and note down service voltages and currents of fan and compressor motors.

Test the safety controls.

Check and note down wet bulb and dry bulb temperatures at evaporator inlet and outlet.

Check suction and discharge pressure using the manifold.

Measure and register the system superheat.

Measure and register the system subcooling.

Annual Maintenance

Perform all recommended quarterly and monthly maintenance services.

Ask a qualified technician to verify the adjustment and operation of each control, and also inspect and replace contactors or controls, if necessary.

Remove cabinet panels and eliminate rust points.

Replace defective thermal insulation and hardware.

Touch up internal and external paintings, if required.

Eliminate oxidation.

Inspect the condenser pipes and clean them, if required.

Inspect the expansion valve bulb for cleaning. Clean it, if required. The contact between the bulb and the suction line must be excellent and adequately isolated.

Measure the compressor motor electric insulation.

IMPORTANT

If equipment preventive maintenance is not performed, this may result in loss of performance and the equipment warranty can even become void.

Corrective Maintenance

Compressor Installation

The compressor may have problems mainly at two levels: mechanical or electric. In both cases, the compressor must be replaced, but keep in mind that this replacement is not enough. It is always important to locate and eliminate the cause(s) of the failure(s).

Mechanic Breakdown

If the compressor has no service valves, transfer the refrigerant to an appropriate cylinder, perform a pressurization test (maximum 200 psig to protect low pressure regulator), make new vacuum, refrigerant load and new start with all readings. Correct the installation to solve any problems that have affected the equipment, releasing it to normal operation and always perform follow-up using the services of a qualified company. In case the compressor has service valves, the refrigerant can remain in the circuit.

- 1.1. Turn the compressor electric circuitry off and remove electric cables (mark them);
- 1.2. Close compressor suction and discharge valves;
- 1.3. Remove the welding in the connections of the compressor to suction and discharge pipes;
- 1.4. Remove the compressor;
- 1.5. Install the new compressor
- 1.6. Install the electric circuitry and pressure regulator tails;
- 1.7. Evacuate the compressor;
- 1.8. Open compressor valves.

Motor Burnout

The motor burnout results in the production of acids and deposition of oxides and sludge in parts of the circuitry. Thus, it is necessary to replace the refrigerant and the oil, as well as to clean all circuit and place HH antiacid dryer filters in liquid and suction lines. In

this case, cleaning should proceed as follows:

- 2.1. Collect all refrigerant in a cylinder and send it to the manufacturer for recycling, or recycle it using appropriate equipment.



WARNING!

Never release gas into the environment; always use appropriate equipment.

- 2.2. Remove the compressor;
- 2.3. Remove the dryer filter;
- 2.4. Install the adequate filter in the compressor suction line and replace the one in the liquid line;
- 2.5. Install the new or recovered compressor, evacuate and load the system;
- 2.6. Check contactors for cleanliness. If required, replace them;
- 2.7. Start the equipment and observe its operation;
- 2.8. Verify pressure loss through the suction filter. If it exceeds the manufacturer-recommended value, replace the filter;
- 2.9. After 24-hour operation, analyze oil;
- 2.10. Change oil and filters every 48 hours until oil is free of acidity;
- 2.11. Remove the suction filter.

When cleaning a circuit with two compressors, replace burnout compressor oil and its pair.

Leakage tests with nitrogen

The leakage test should be performed after the installation of interconnection tubing of separated units, whenever the liquid sight glass shows bubbling or after repairs in the equipment refrigerating circuit.

Use refrigerant as a test element to detect leakage and dry nitrogen to achieve the test pressure.

Evacuation

- Evacuation is required to remove water steam and non-condensable gases from the system;
- Use rotary style high vacuum pump;
- Install the set manometer-manifold.
- A vacuum of at least one hour is recommended to perform the first reading. The evacuation is only completed when the final vacuum is between 250 and 500 microns. As a release test, the pump register should be closed for 5 minutes and the vacuum should not exceed 100 microns.



WARNING!

Always use pressure regulator valve in the dry nitrogen cylinder to test leakage. If this valve is not used, there may be fatal consequences due to explosion.



WARNING!

Under no circumstances use oxygen or acetylene instead of dry nitrogen to test leakage. Undue use of such gases may have fatal consequences, as explosions, chemical reactions or other reactions can occur.

IMPORTANT

The follow-up of a perfect evacuation must be performed using proper equipment, and never measured in relation to evacuation time, but in reference to negative pressure: 250 to 500 microns.

VI-Operational and Electric Features

Tab. VI-01 - Compressor Electrical Characteristics - 50 Hz

Capacidade Nominal	kW		CNO	CMO	CRT
	(Nominal)	(Máximo)			
	380V	380V	380	380	380
5	4,16	5,20	7,80	9,50	61,80
7,5	5,96	7,45	10,50	12,20	101,00
10	9,00	11,50	15,80	19,10	118,00
15	13,60	17,00	25,60	30,40	173,00
20	18,20	22,82	30,89	37,30	215,00
25	22,83	28,82	39,17	47,23	270,00

Tab. VI-02 - Compressor Electrical Characteristics - 60 Hz

Nominal Capacity	kW (Nominal)			kW (Máximo)			RLA			FLA			LRA		
	220V	380V	440V	220V	380V	440V	220	380	440	220	380	440	220	380	440
5		5,0			6,3		15,4	9,3	7,7	18,1	11,1	9,1	124,0	75,0	60,0
7,5		6,95			8,75		20,8	11,8	11,0	25,2	14,9	12,9	164,0	100,0	100,0
10		10,9			13,6		32,6	19,7	16,3	39,2	23,7	19,6	239,0	145,0	125,0
15		16,8			20,8		53,2	32,0	26,5	62,6	37,7	31,3	340,0	196,0	173,0
20		22,13			27,7		71,1	42,0	31,2	86,8	51,2	38,2	460,0	260,0	215,0
25		27,5			34,8		89,8	53,3	39,5	110,0	65,3	48,4	560,0	305,0	270,0

Notes:

- (1) RLA = Rated Load Amps (A)
- (2) FLA = Full Load Amps (A)
- (3) LRA = Locked Rotor Amps (A)

Tab. VI-03 - Normal operational conditions

1. High Pressure	200 to 340 psig
2. Low Pressure	54 to 80 psig
3. Overheating	8°C to 12°C
4. Subcooling	5°C to 10°C
5. Liquid Sight Glass	Refrigerant flow with no traces of gas
6. Voltage (V)	Must not exceed +/- 10% of nameplate voltage
7. Current (A)	Must not exceed the nameplate current



WARNING!

Never connect a jumper to protection and safety devices, so as to avoid damages to motors and compressors, as well as to preserve the physical integrity of operators and maintenance personnel.

Tab. VI-04 - Control Adjustment

Control	Cutout	Reset	Notes
High Pressure Regulator	395 +/- 15 psig	280 +/- 20 psig	Air Condensation
Low Pressure Regulator	25 +/- 8 psig	80 +/- 12 psig	For both
Motor Coil Thermostat	105°C	82°C	For both

Notes:

- (1) Subcooling measure must be done on saturated liquid data.
- (2) Overheating must be done on saturated heat data.

VII-Wiring Diagram

Fig. VII-01 - Wiring Diagram - Start - CXPA 050 to 500

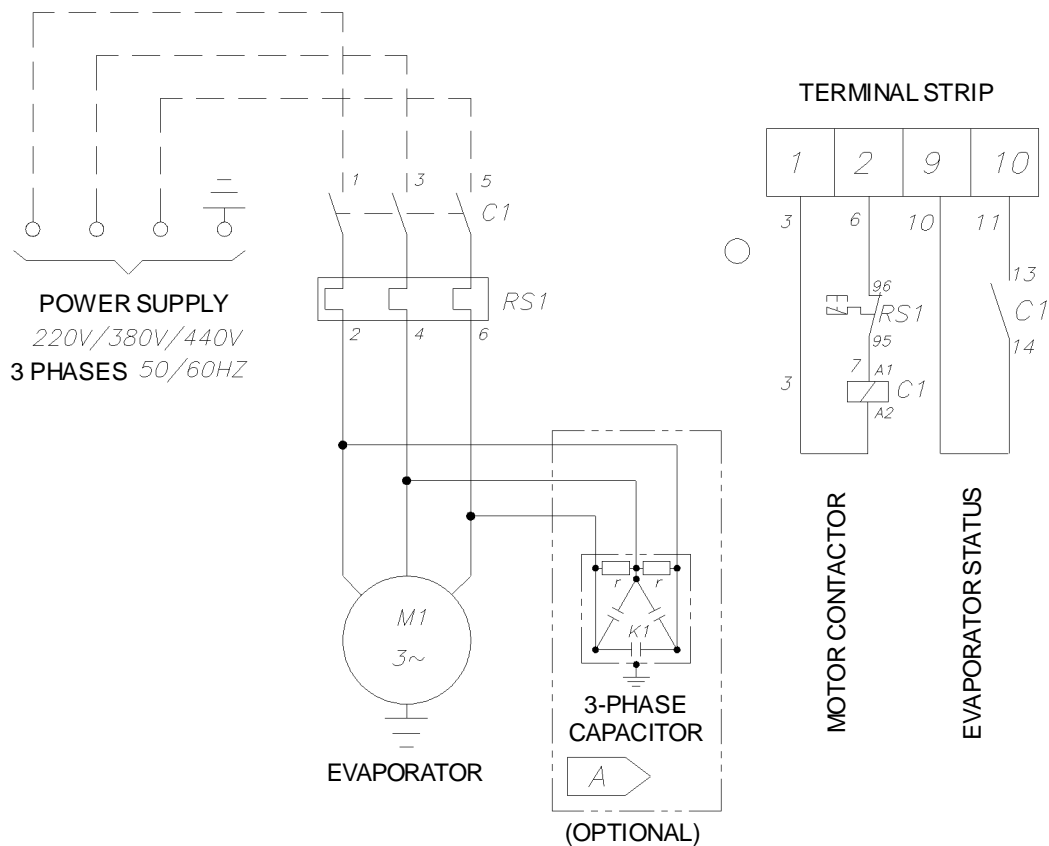

Wiring Diagram

Fig. VII-02 - Wiring Diagram of strength and command TRAE 050/075/100/125/150

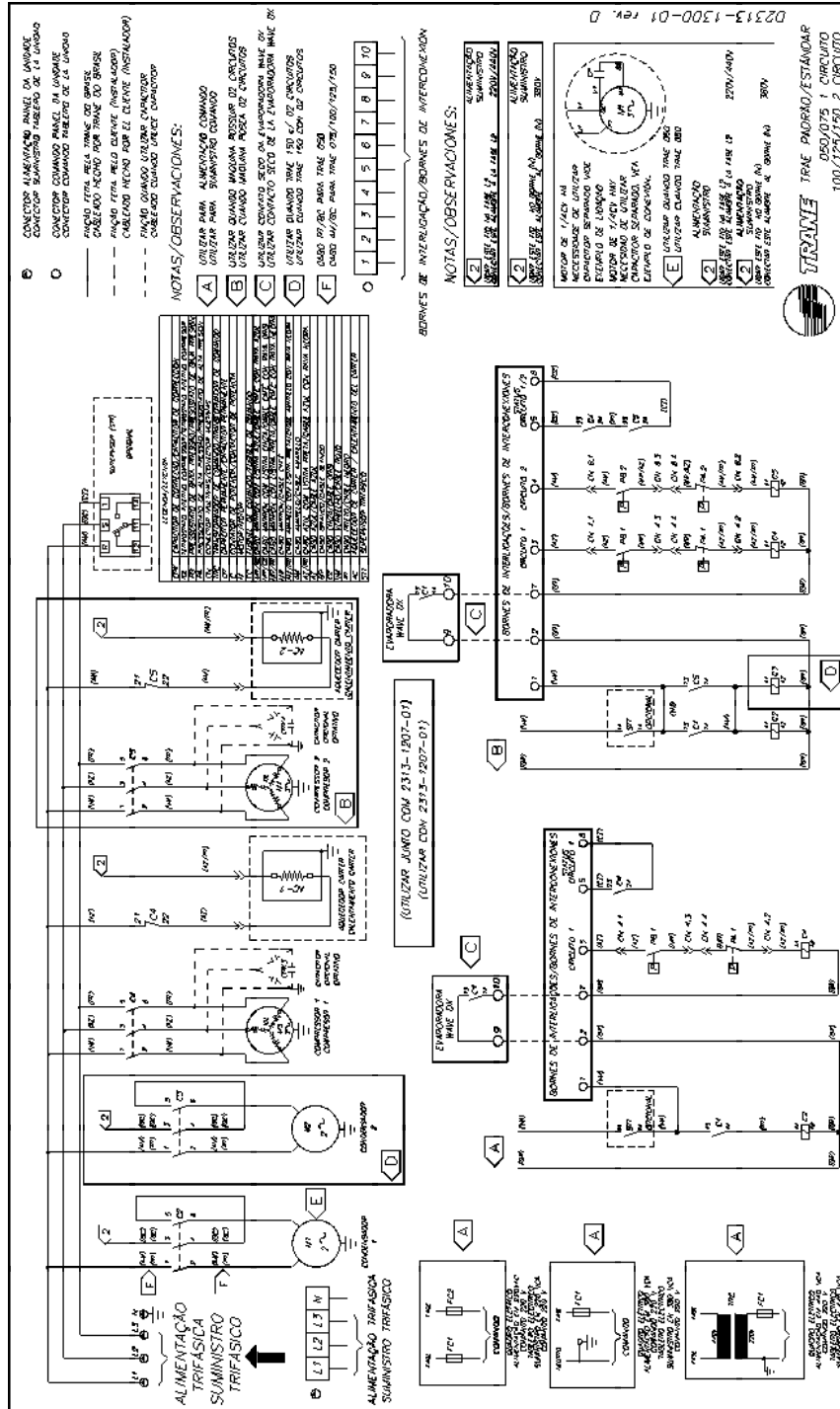

Wiring Diagram

Fig. VII-07 - Wiring Diagram of strength and command TRAE 050 - with RTRM

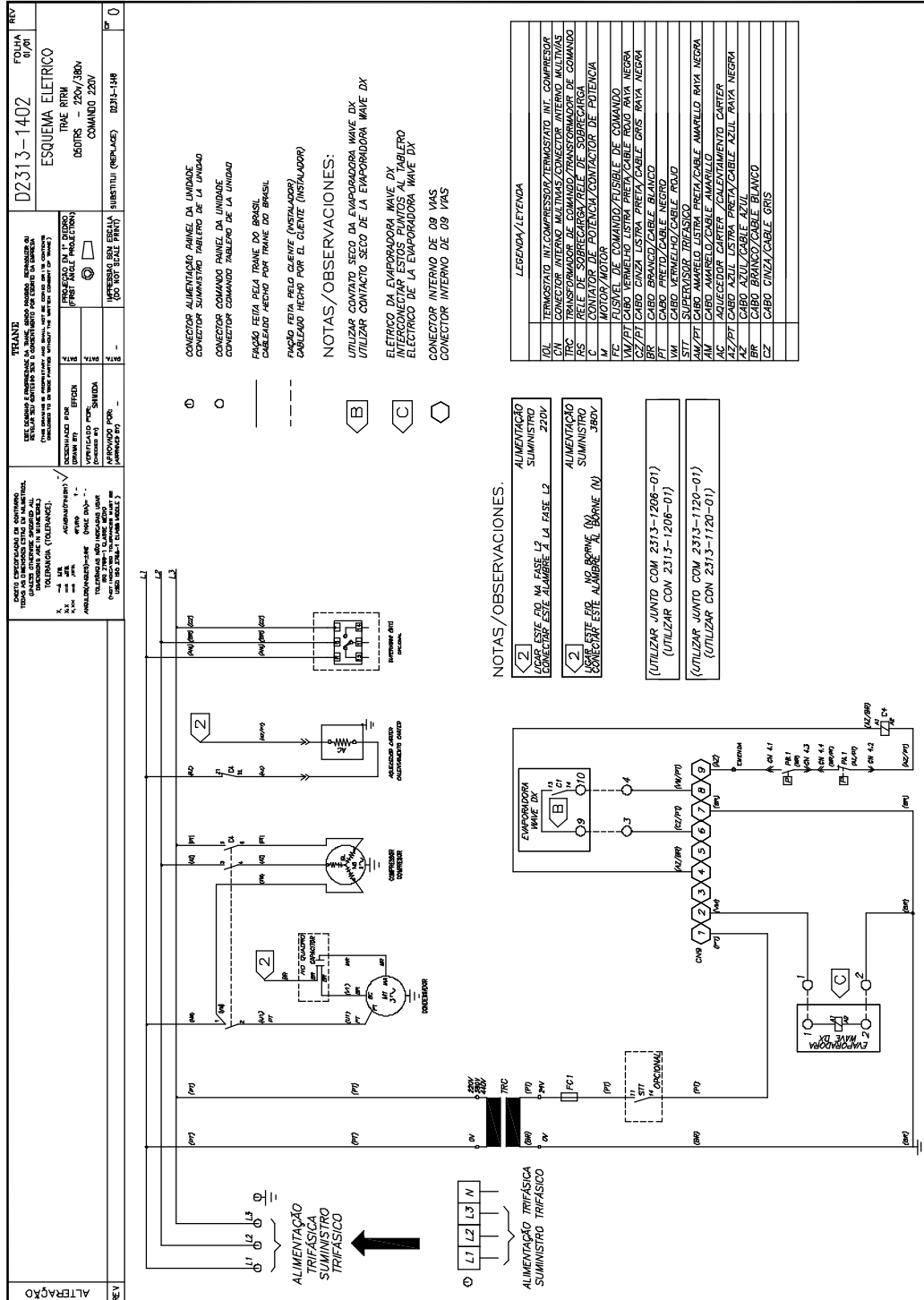

Wiring Diagram

Fig. VII-08 - Wiring Diagram of strength and command TRAE 200/250 - 1 circuit

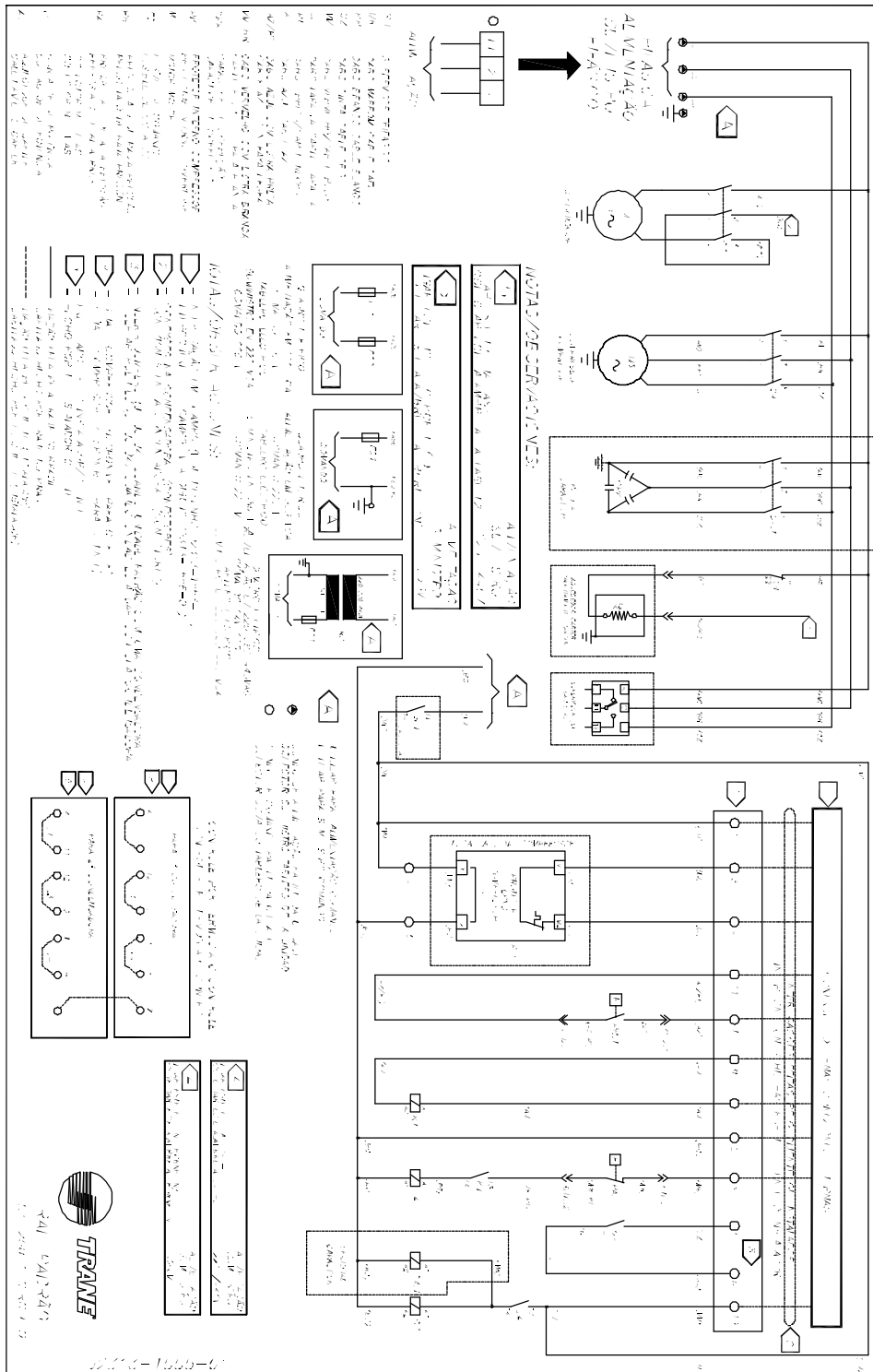

Wiring Diagram

TRAE

Fig. VII-10 - Wiring Diagram of strength and command TRAE 200 - 2 circuits

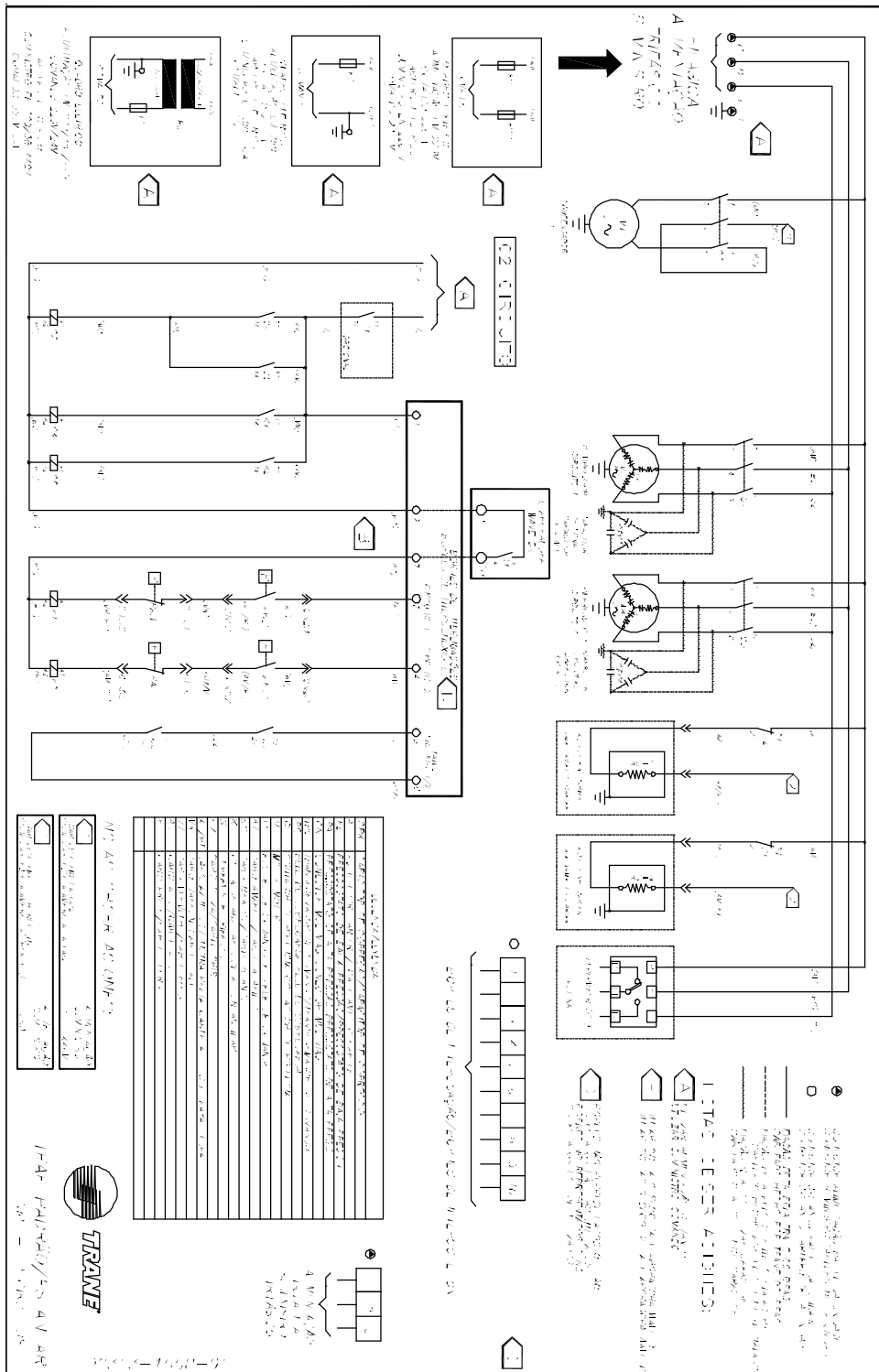

Wiring Diagram

TRAE

Fig. VII-13 - Wiring Diagram of strength and command TRAE 100 - 1 circuit

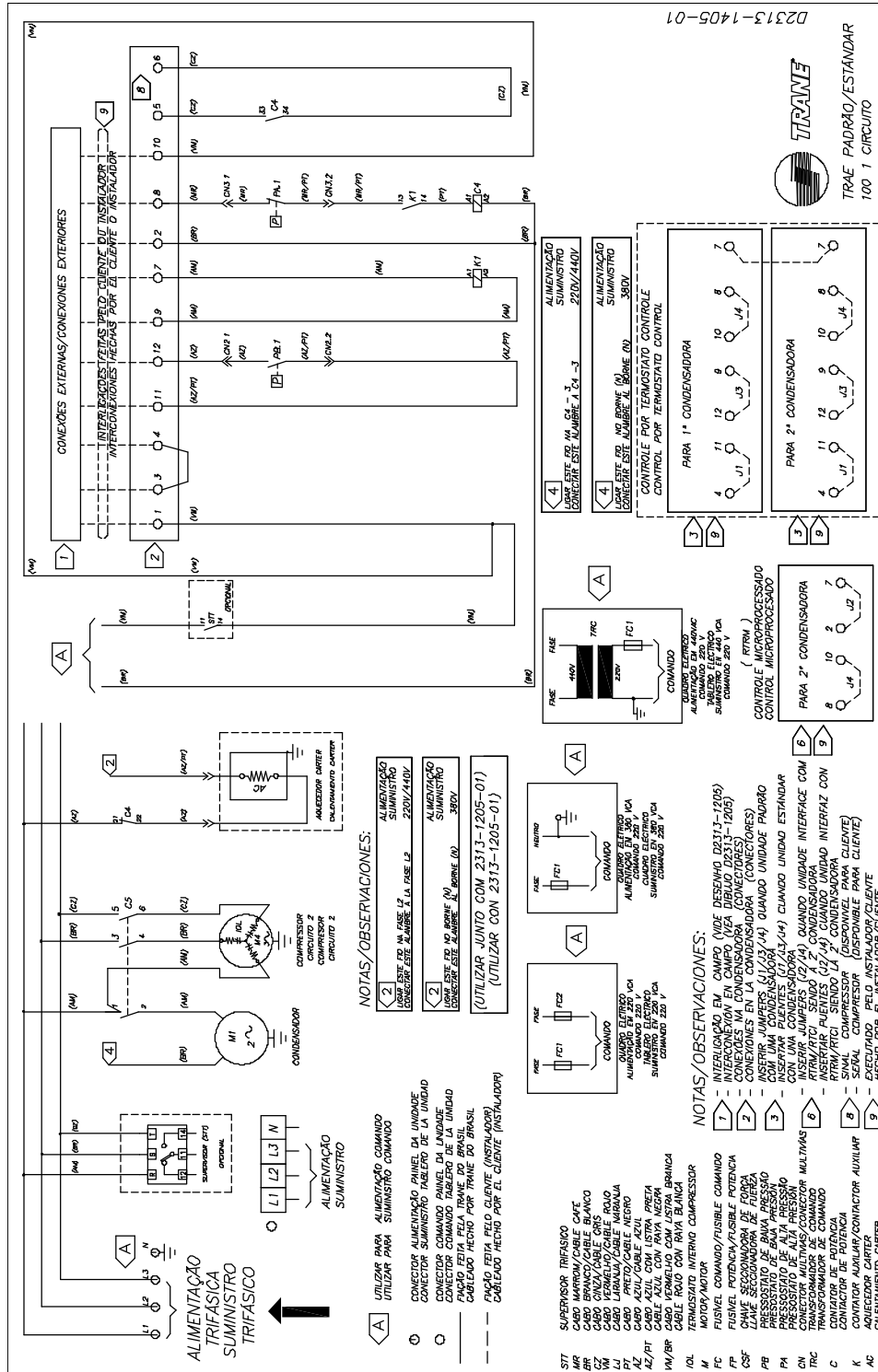

D2313-1405-01



Wiring Diagram

TRAE-RTRM

Fig. VII-15a - Wiring Diagram of strength and command TRAE 200 - 2 circuits

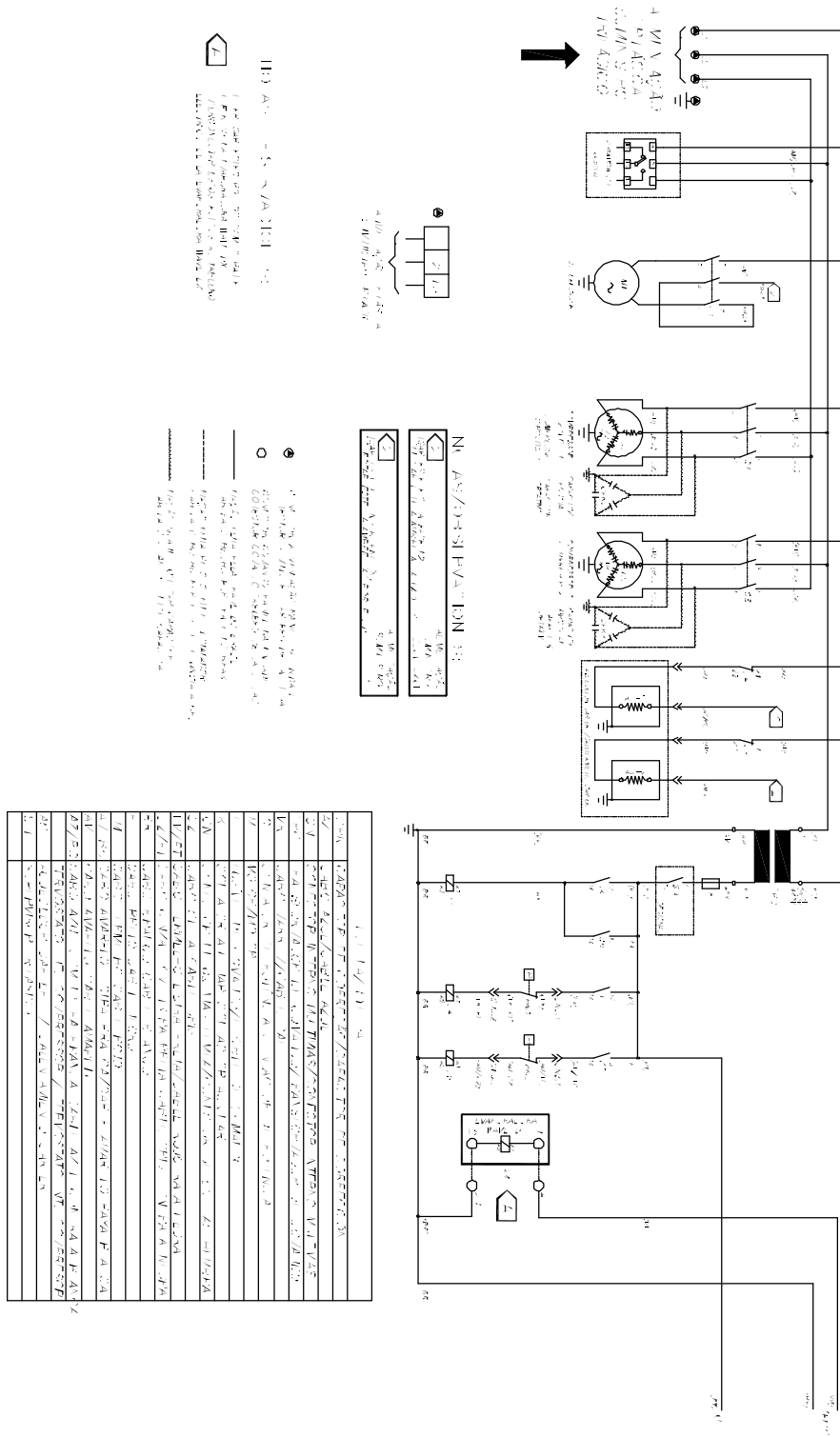

Wiring Diagram

TRAE-RTRM

Fig. VII-15b - Wiring Diagram of strength and command TRAE 200 - 2 circuits

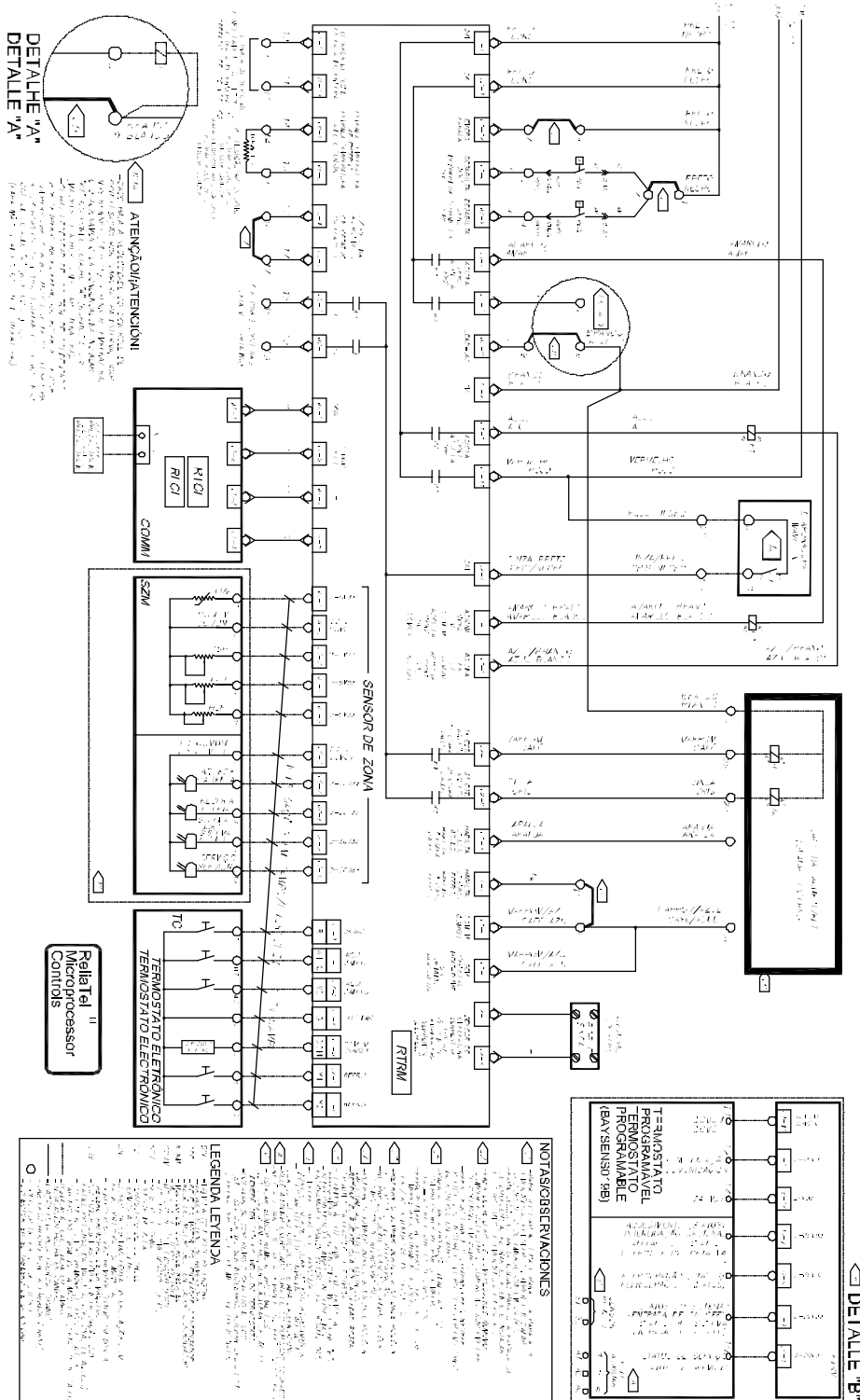

Wiring Diagram

TRAE-RTRM

Fig. VII-17a - Wiring Diagram of strength and command TRAE 250 - 2 circuits

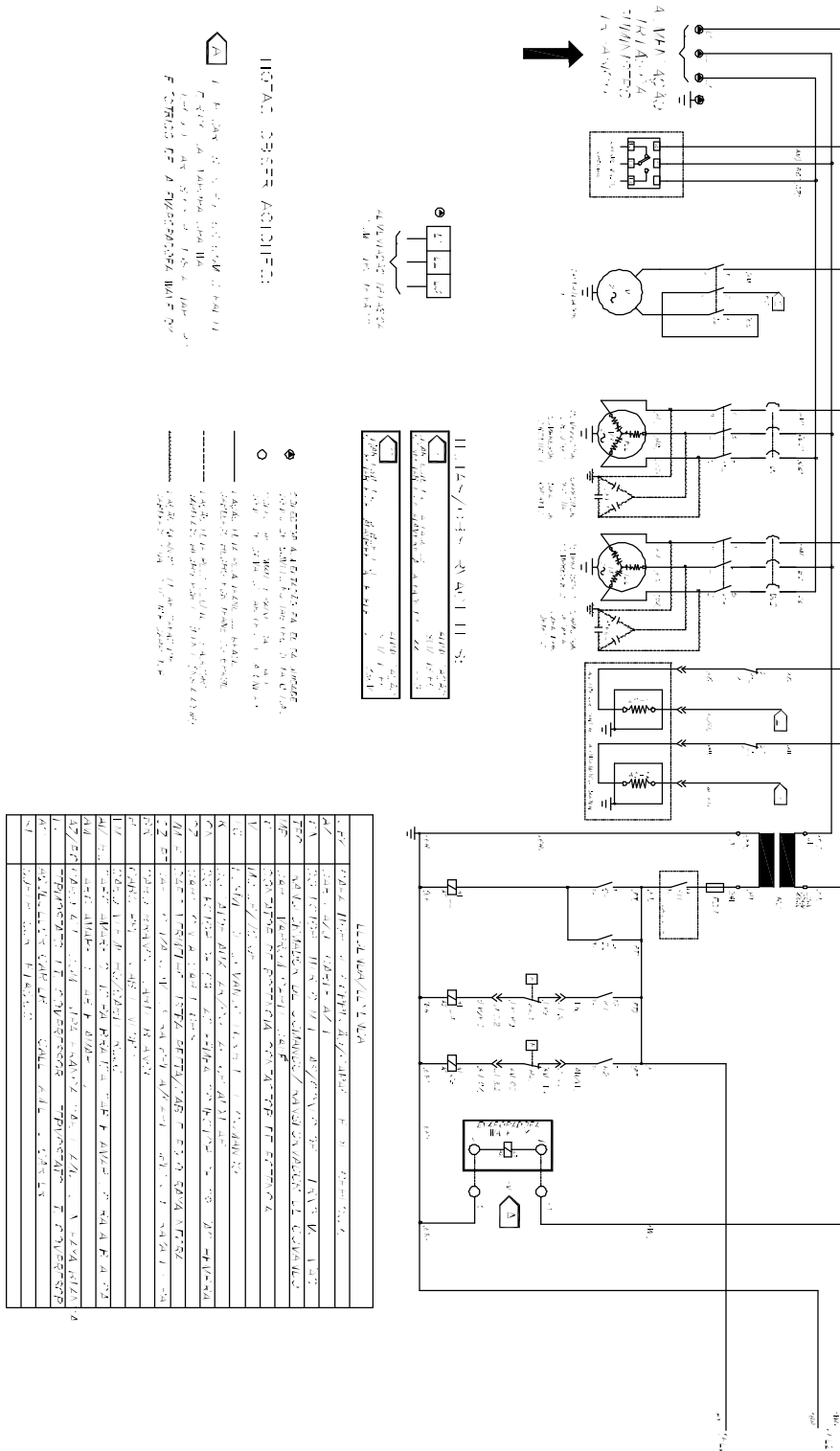

Wiring Diagram

TRAE-RTRM

Fig. VII-17b - Wiring Diagram of strength and command TRAE 250 - 2 circuits

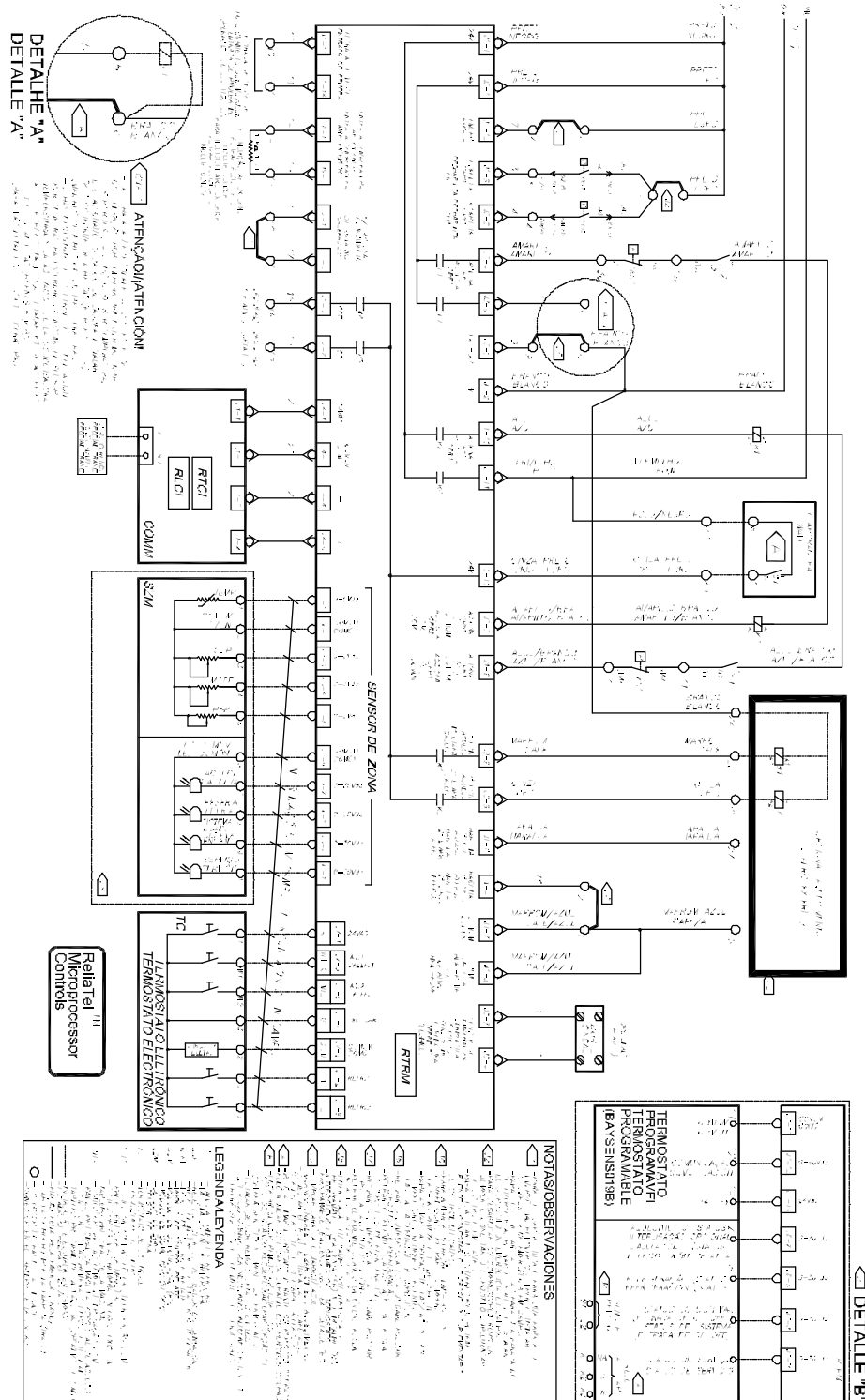

Wiring Diagram

TRAE-RTRM

Fig. VII-19 - Wiring Diagram of strength and command TRAE 300 - 2 circuits

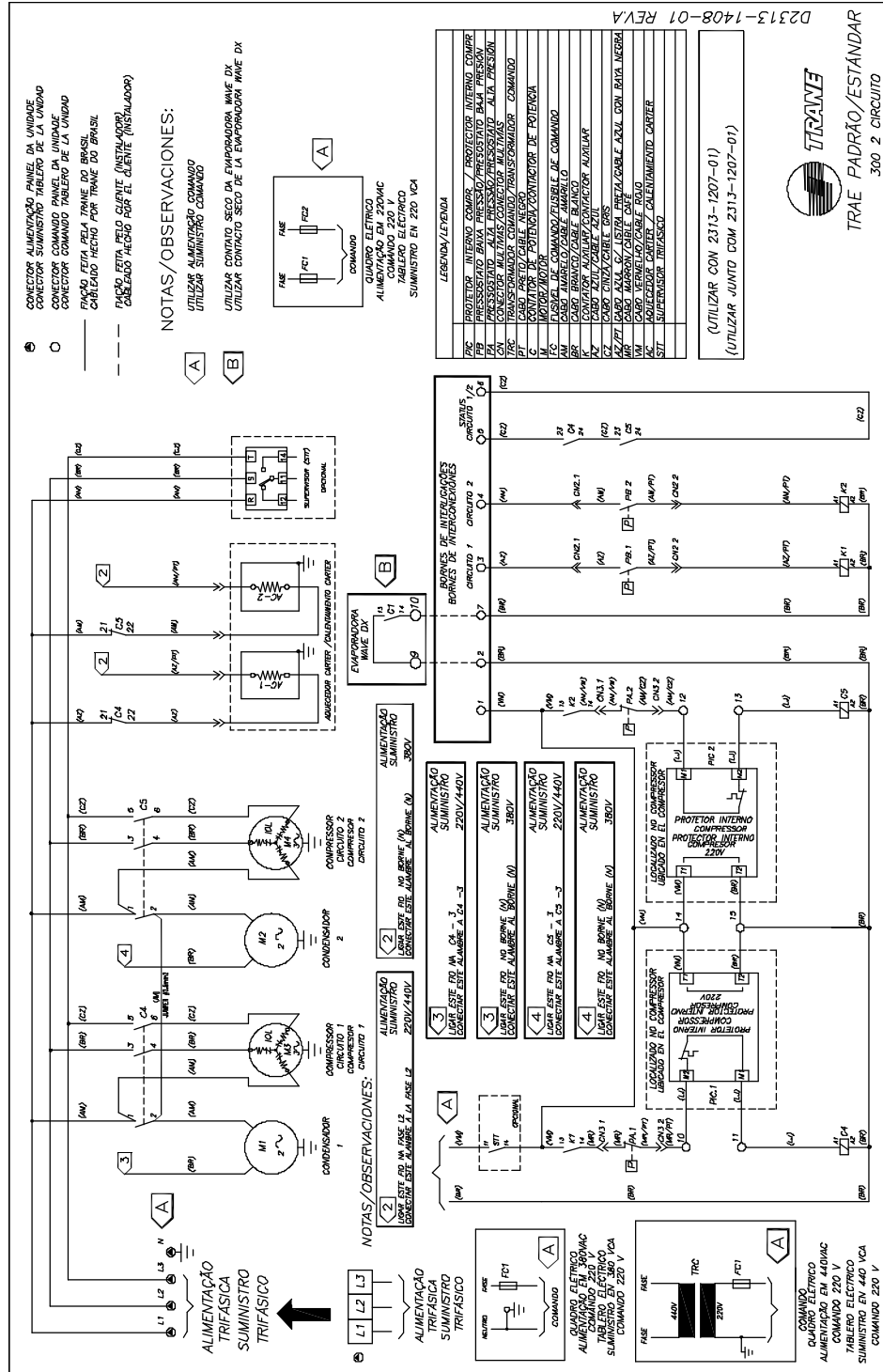

Wiring Diagram

TRAE-RTRM

Fig. VII-20 - Wiring Diagram of strength and command TRAE (RTRM) 150 - 1 circuit

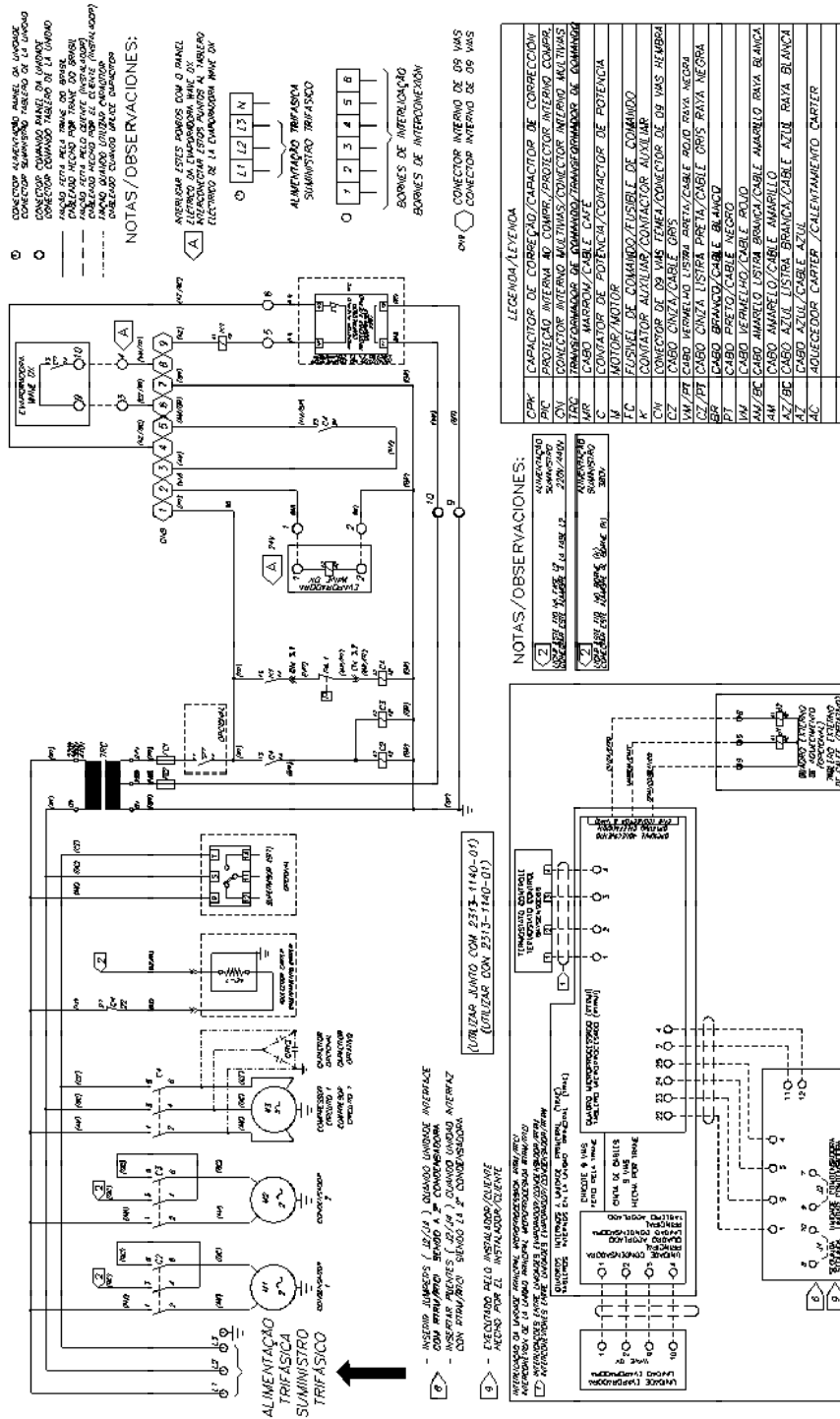

Wiring Diagram

TRAE-RTRM

Fig. VII-22b - Wiring Diagram of strength and command TRAE 200/250 - 1 circuit - With RTRM

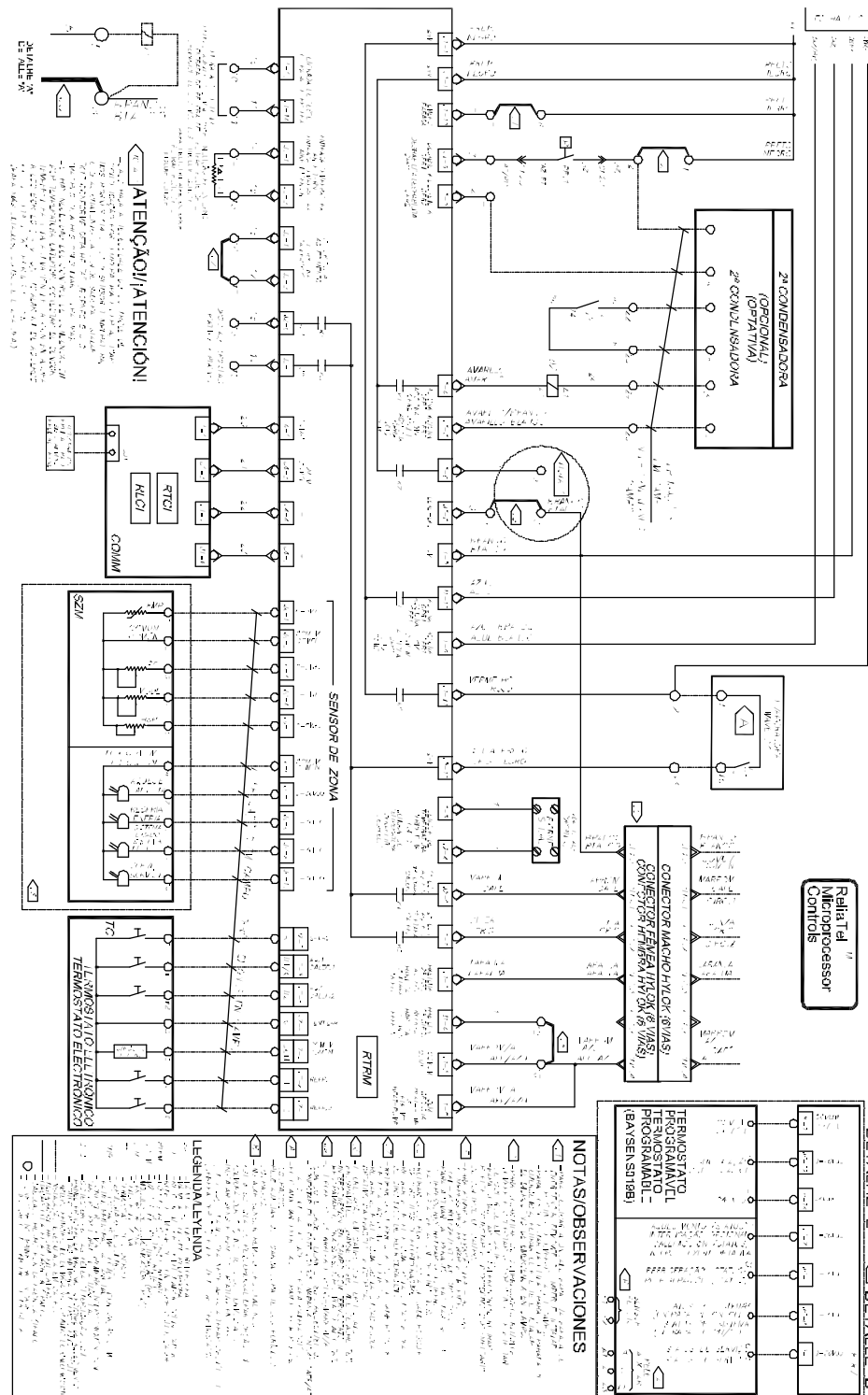

Wiring Diagram

TRAE-RTRM

Fig. VII-24a - Wiring Diagram of strength and command TRAE 200-2 circuits - With RTRM

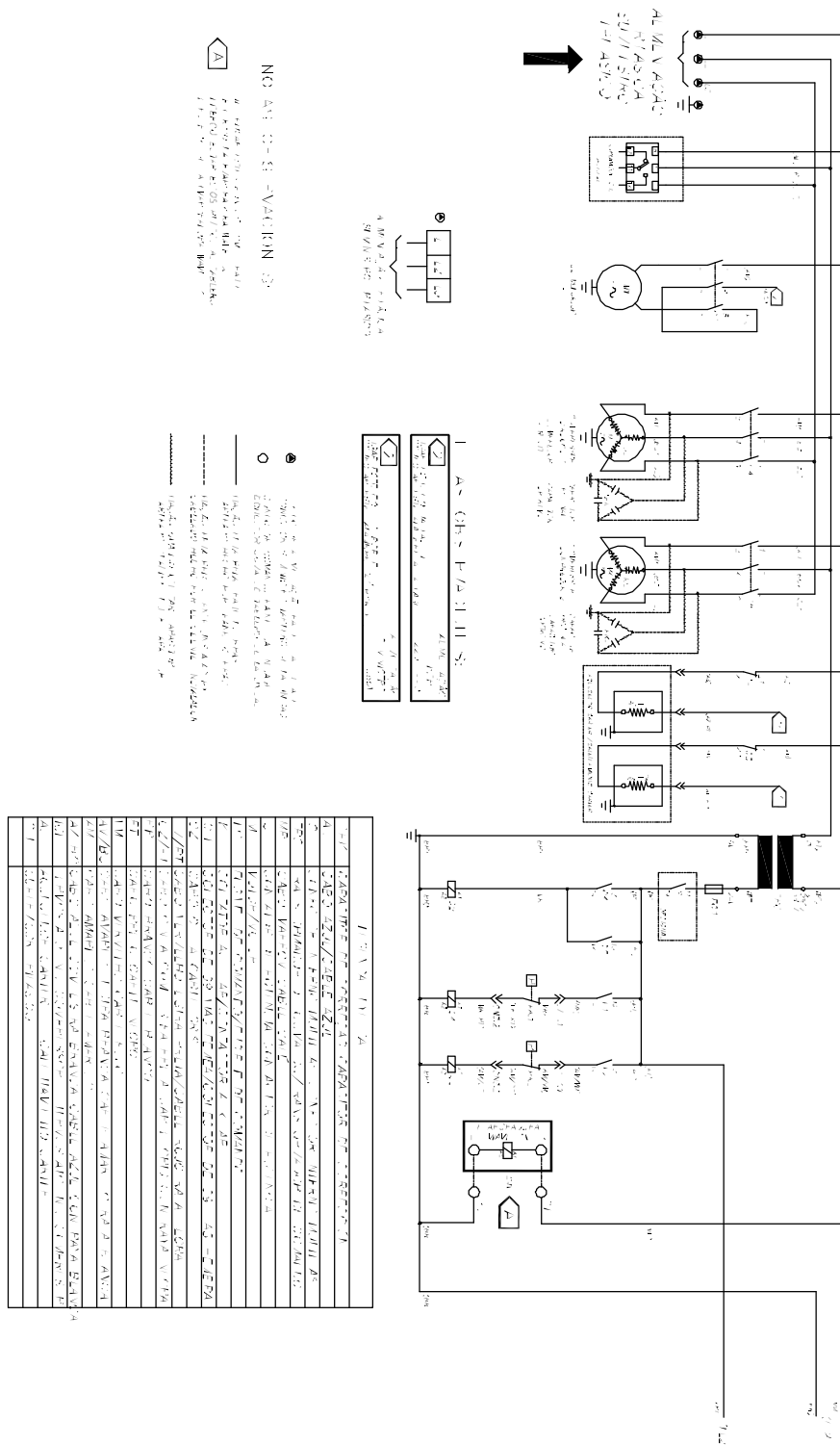

Wiring Diagram

TRAE-RTRM

Fig. VII-25a - Wiring Diagram of strength and command TRAE 200/250 - 1 circuit

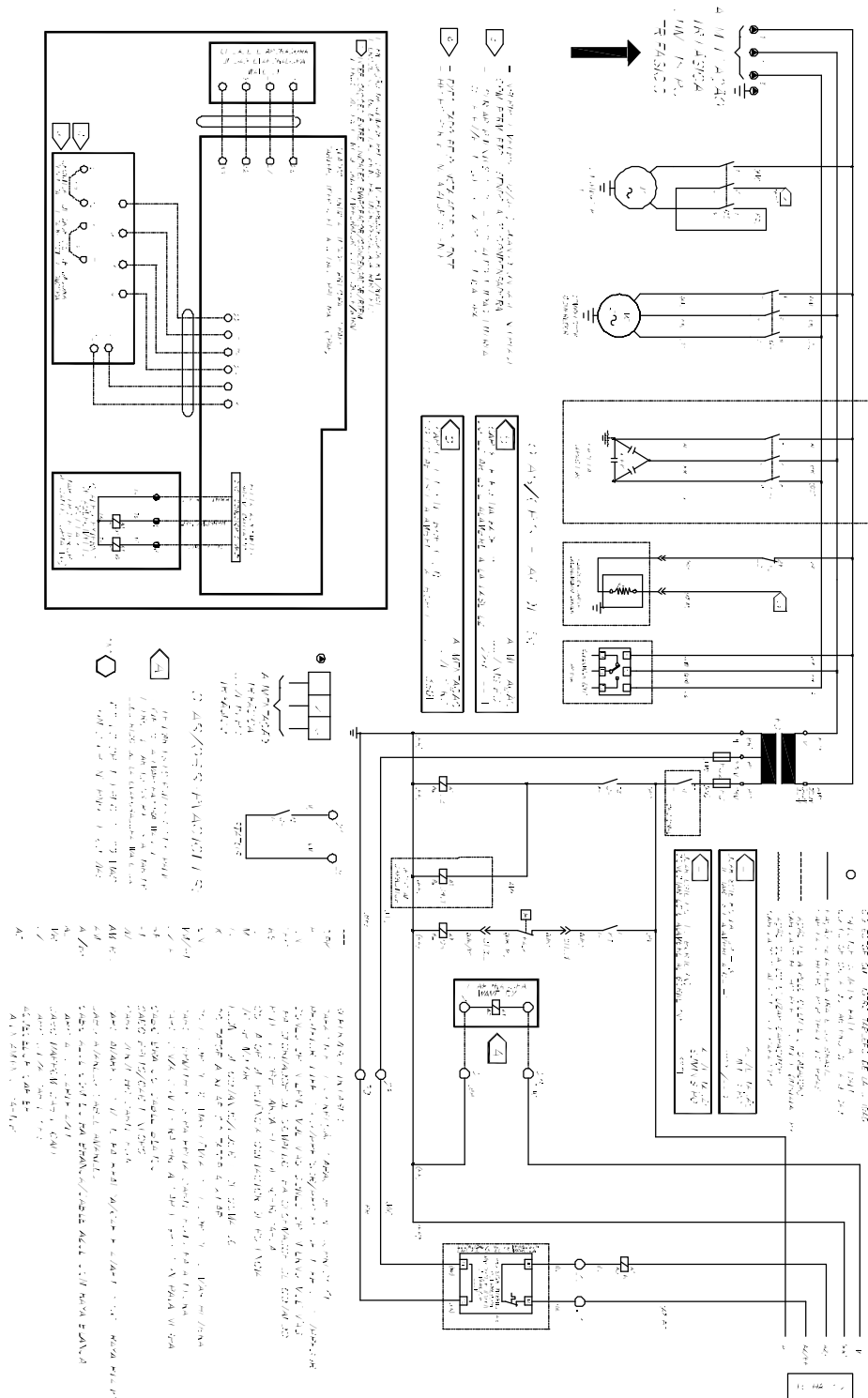

Wiring Diagram

TRAE-RTRM

Fig. VII-25b - Wiring Diagram of strength and command TRAE200/250 - 1 circuit

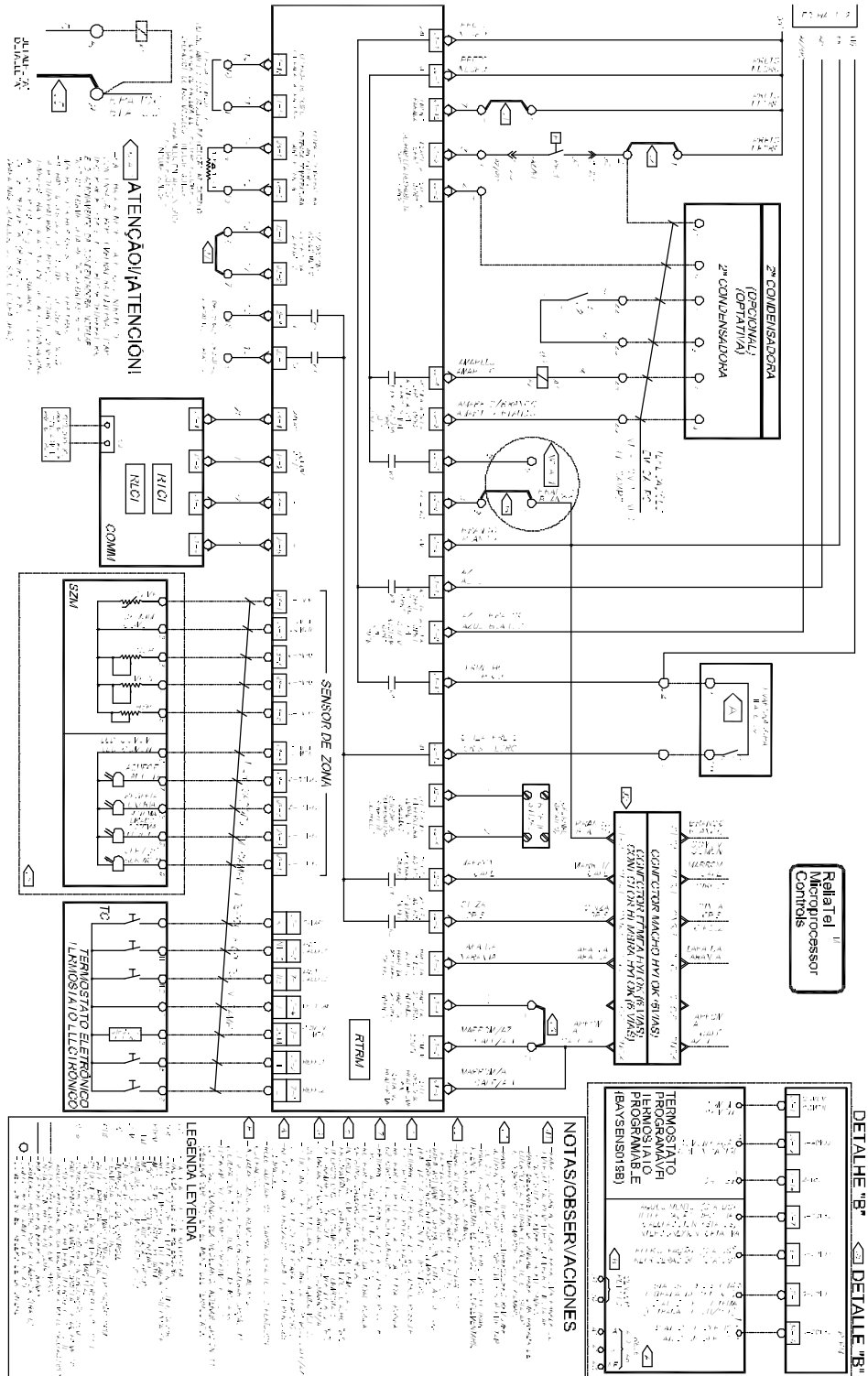

Wiring Diagram

TRAE-RTRM

Fig. VII-26a - Wiring Diagram of strength and command TRAE 250 - 2 circuits - Com RTRM

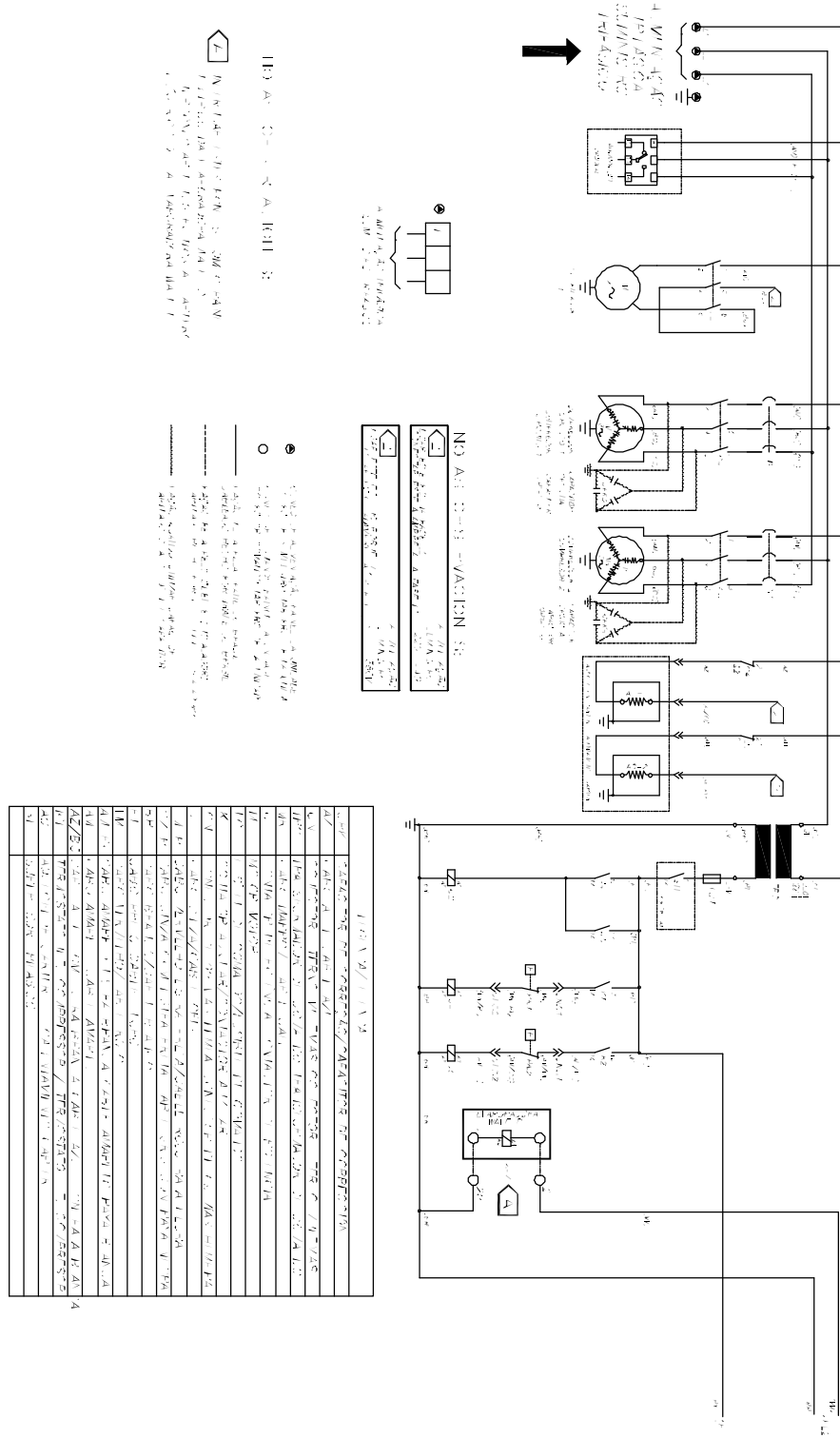

Wiring Diagram

TRAE-RTRM

Fig. VII-26b - Wiring Diagram of strength and command TRAE 250 - 2 circuits - Com RTRM

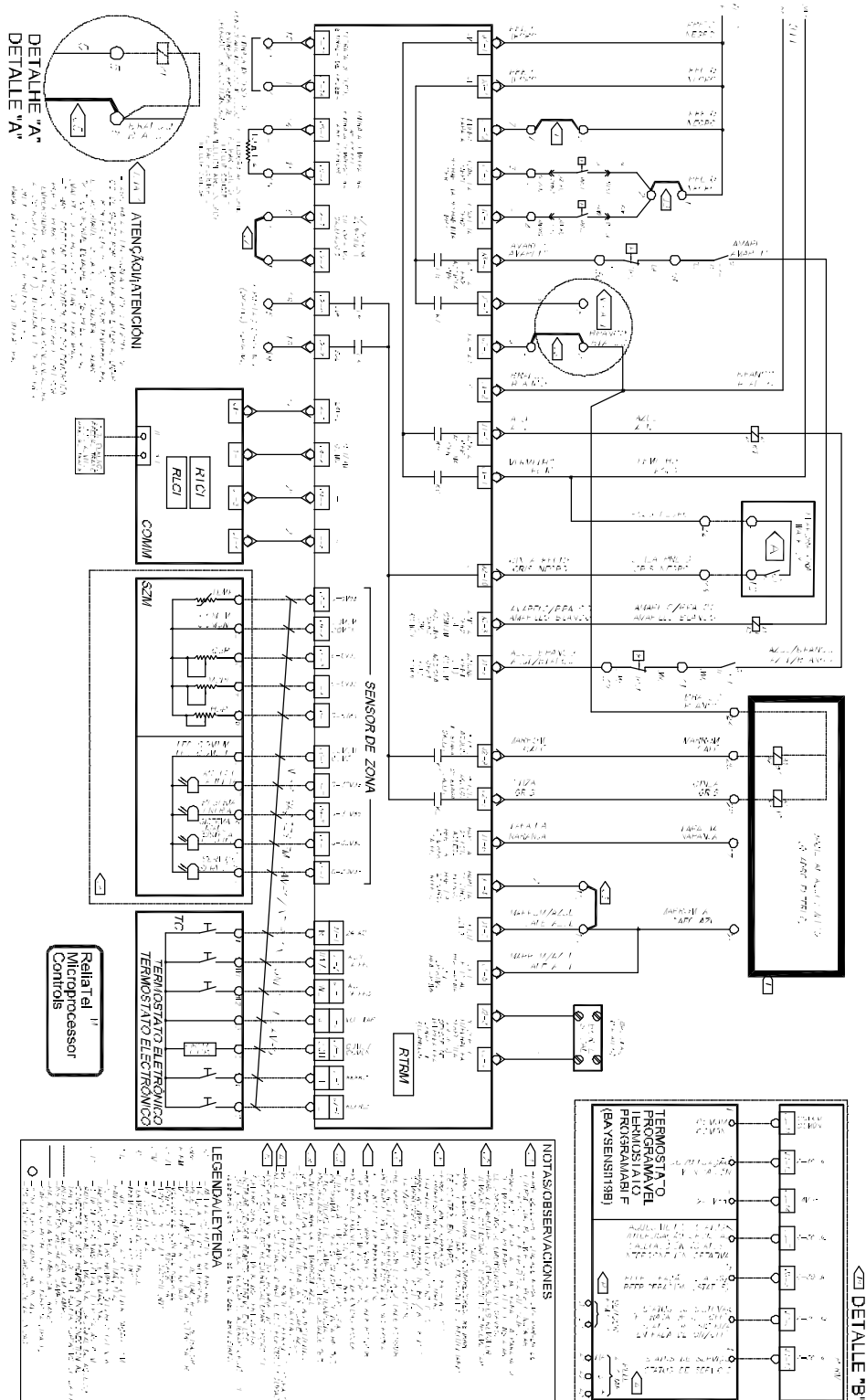

Wiring Diagram

Fig. VII-27 - Wiring Diagram of strength and command TRAE 075/100/125 - With RTRM

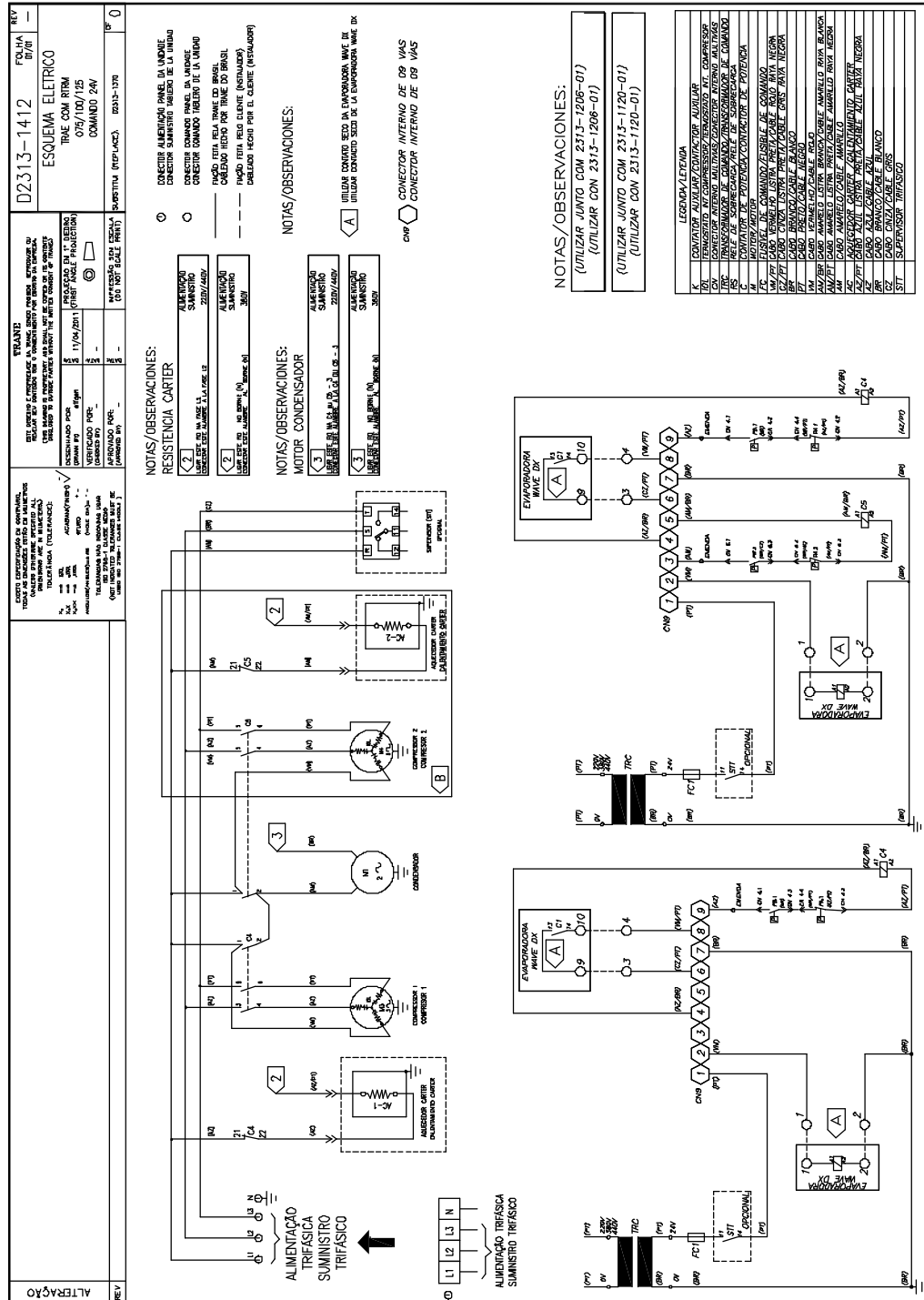

Wiring Diagram

TRAE-RTRM

Fig. VII-28 - Wiring Diagram of strength and command TRAE 300 - 2 circuits - With RTRM

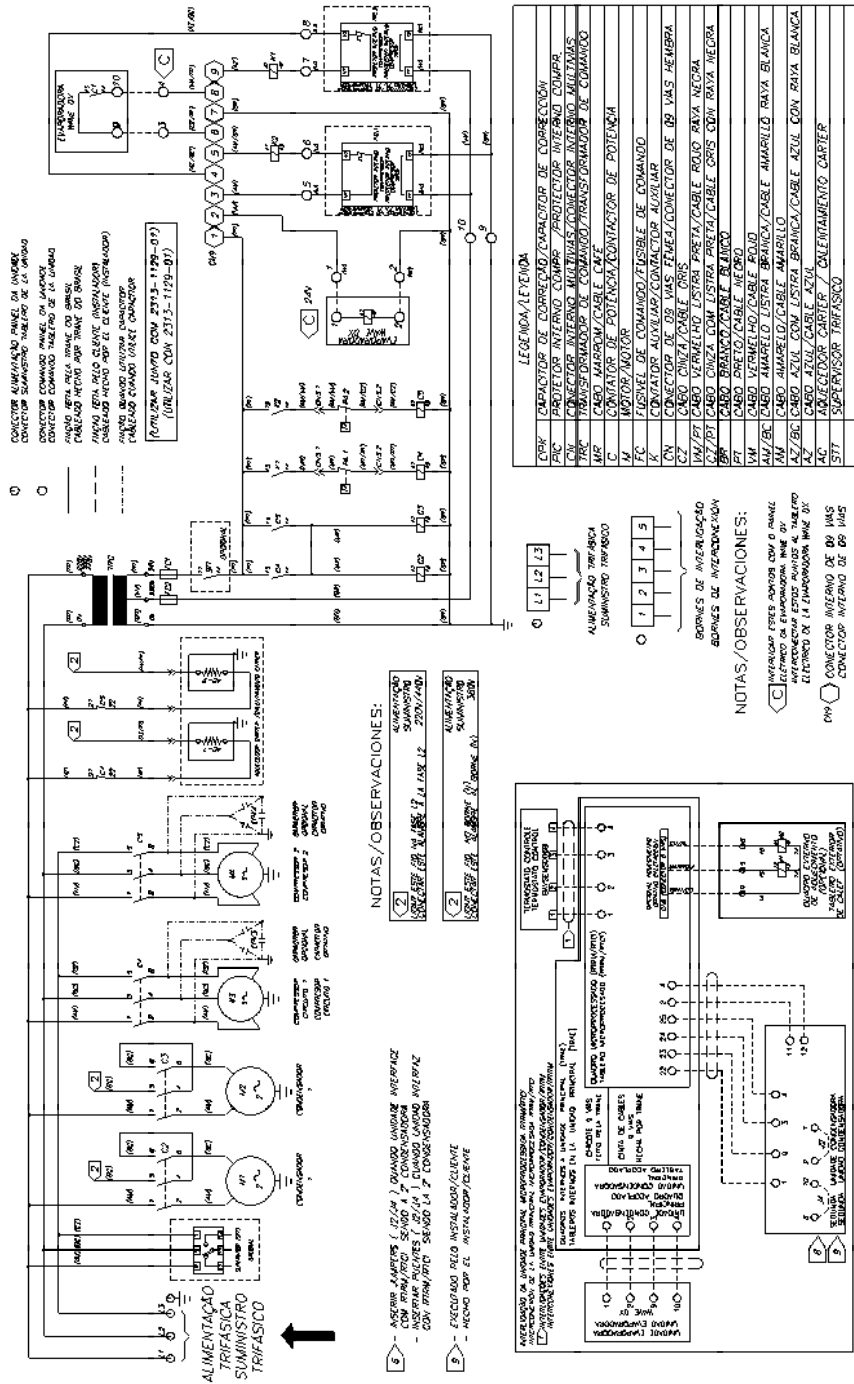

Wiring Diagram

TRAE-RTRM

Fig. VII-30 - Wiring Diagram of strength and command TRAE 150 - 1 circuit - With RTRM

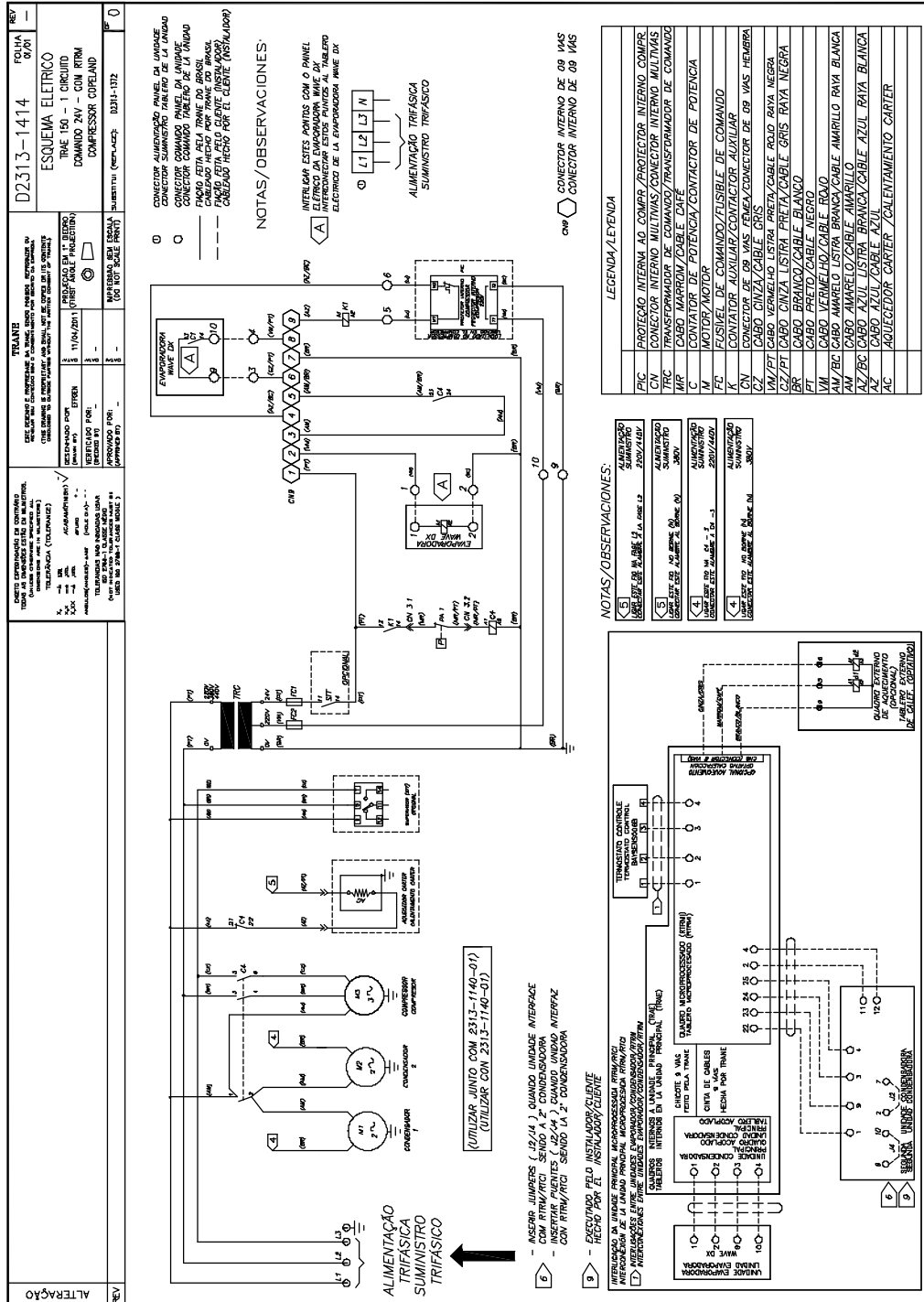

Wiring Diagram

TRAE-RTRM

Fig. VII-31a - Wiring Diagram of strength and command TRAE 200 - 2 circuits - With RTRM

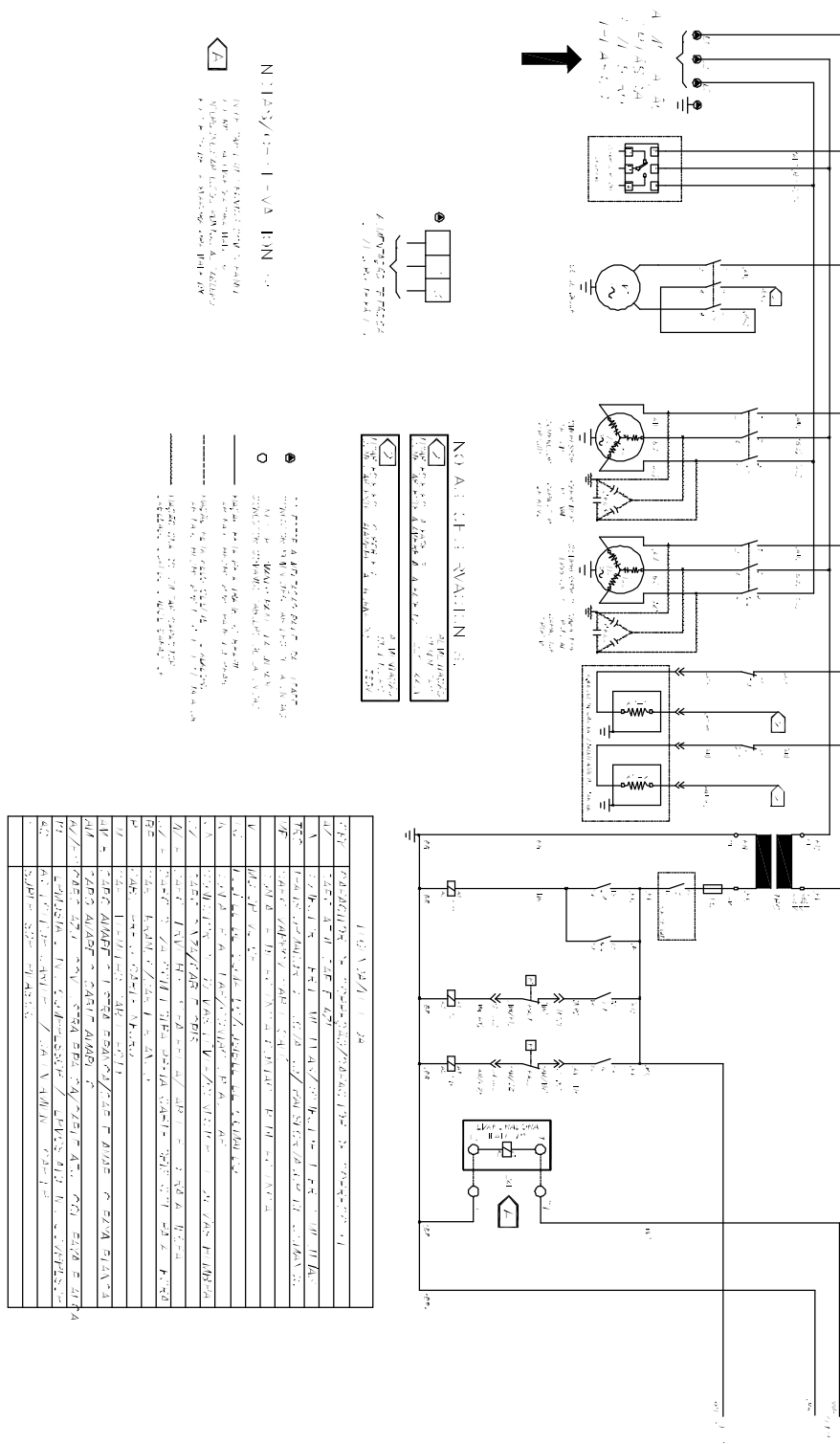

Wiring Diagram

TRAE-RTRM

Fig. VII-31b - Wiring Diagram of strength and command TRAE 200 - 2 circuits - With RTRM

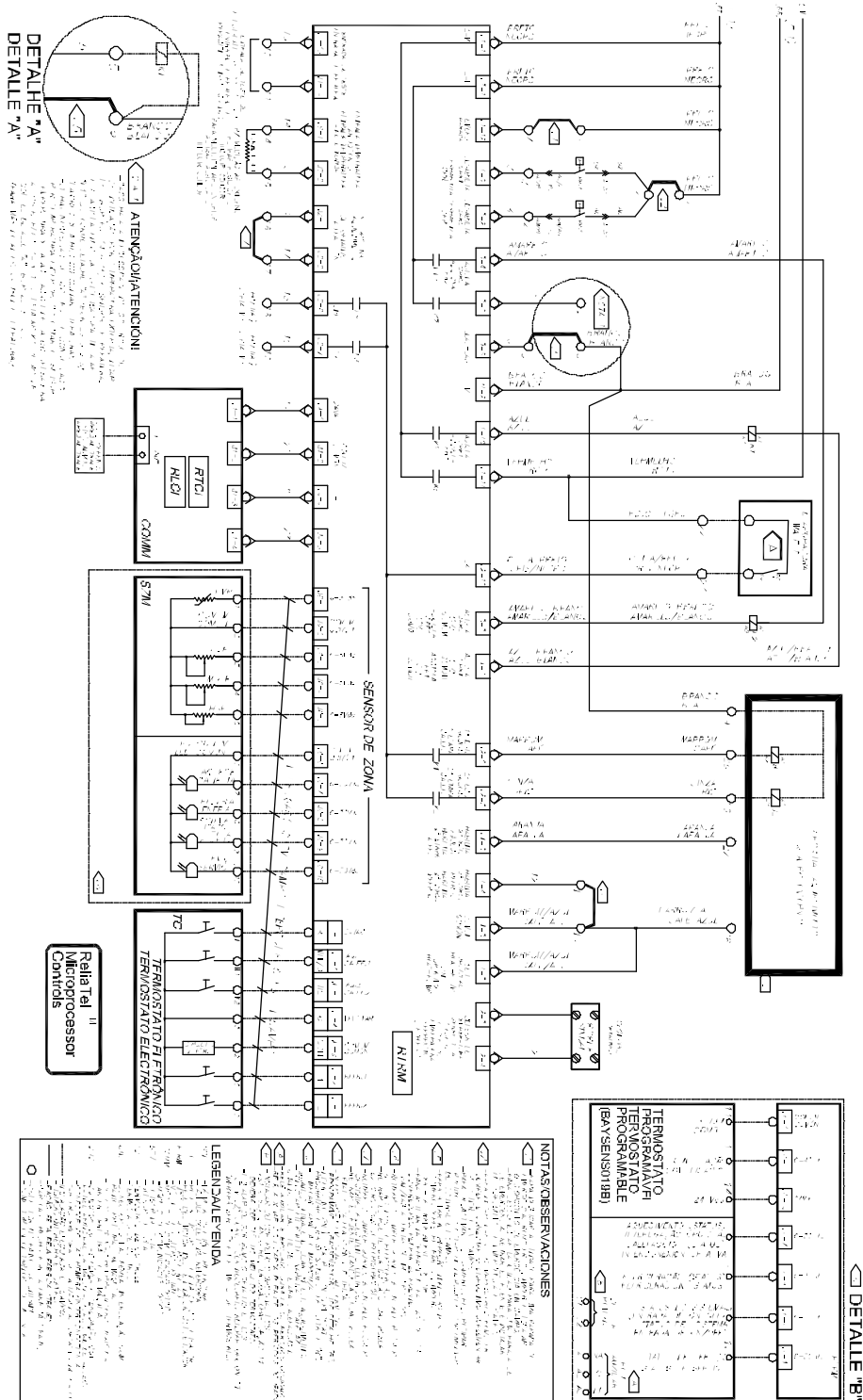

Wiring Diagram

TRAE-RTRM

Fig. VII-32a - Wiring Diagram of strength and command TRAE 250 - 2 circuits - With RTRM

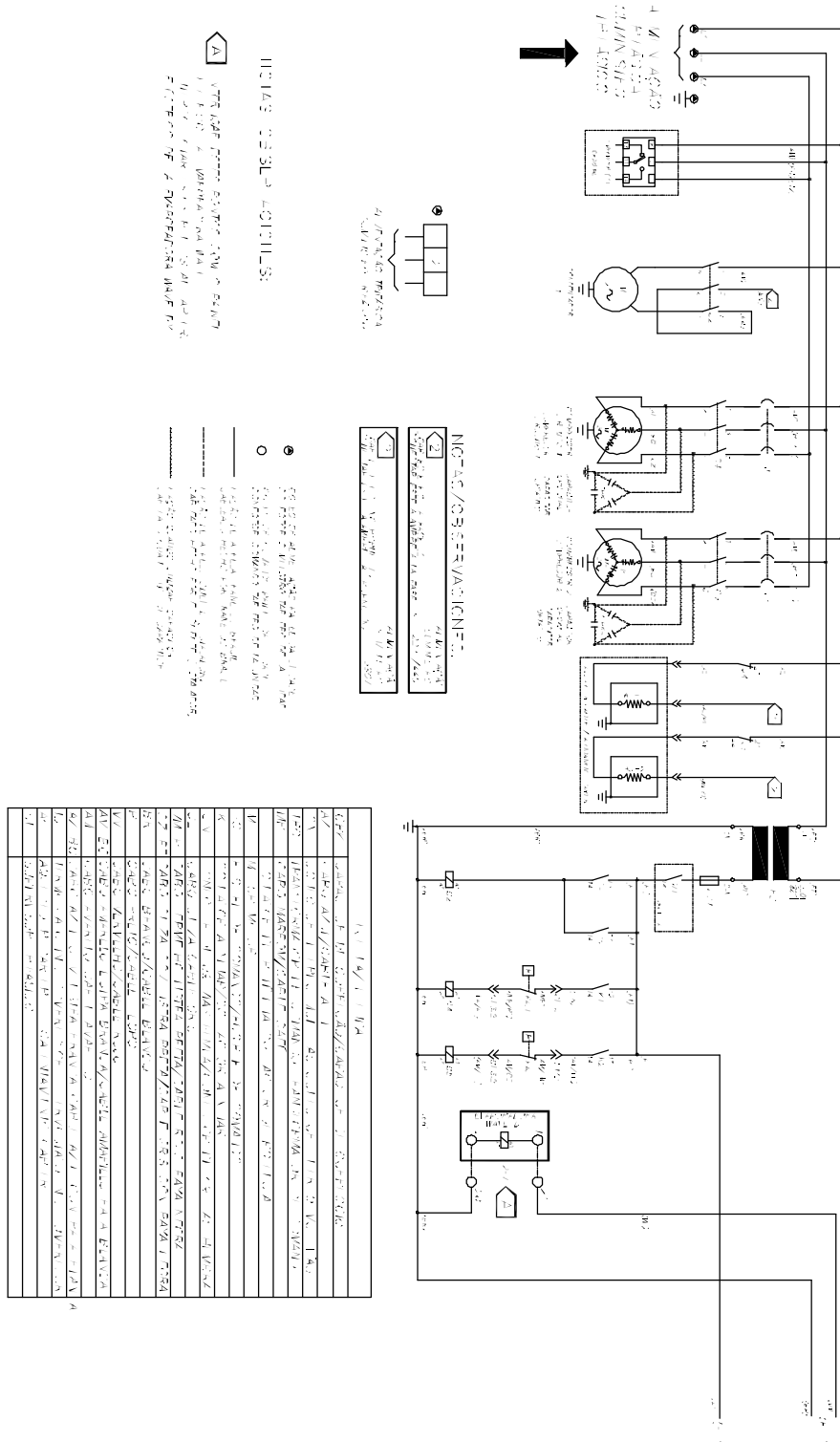

Wiring Diagram

TRAE-RTRM

Fig. VII-32b - Wiring Diagram of strength and command TRAE250 - 2 circuits - With RTRM

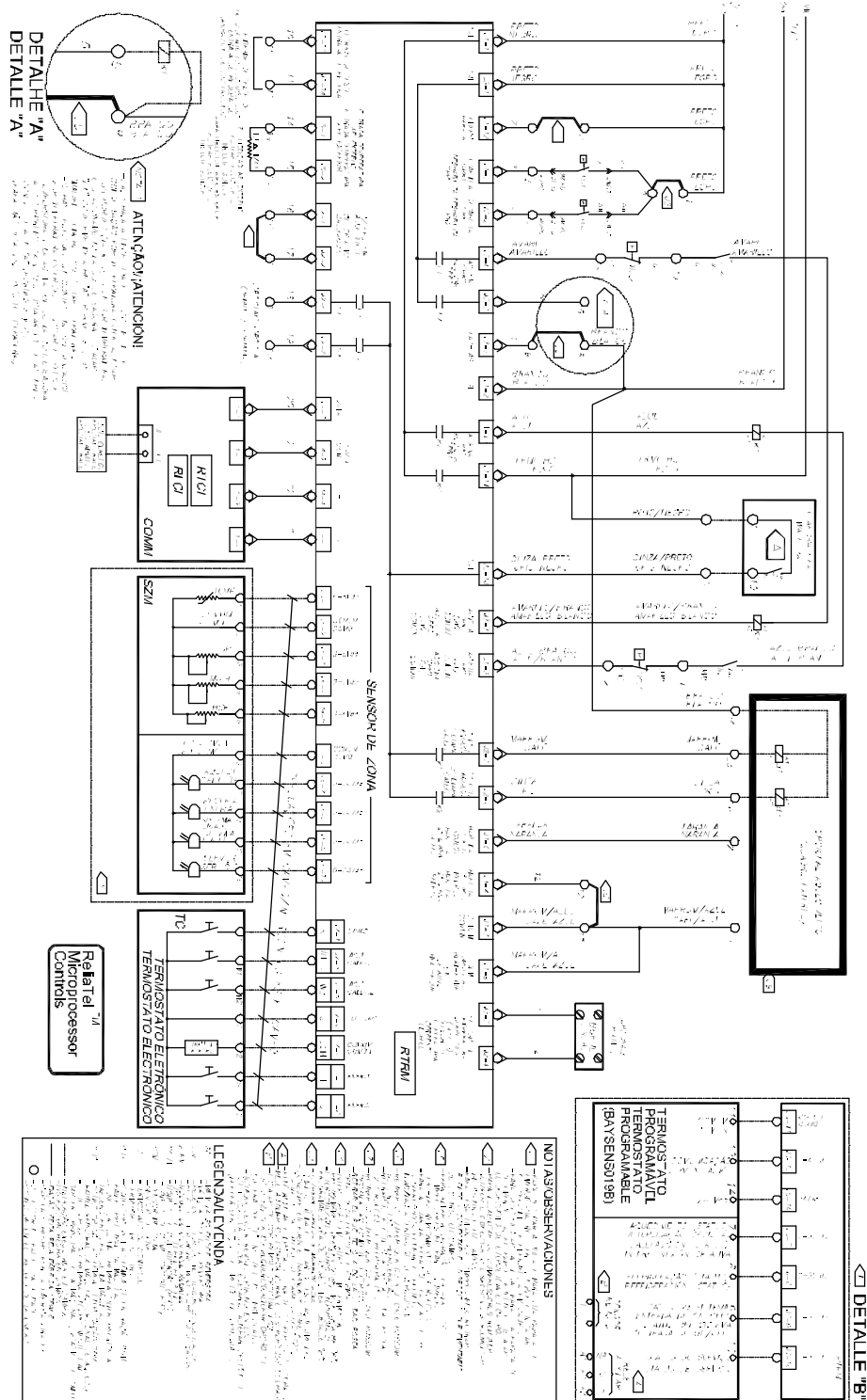

Wiring Diagram

TRAE-RTRM

Fig. VII-33 - Wiring Diagram of strength and command TRAE 300 - 2 circuits - With RTRM

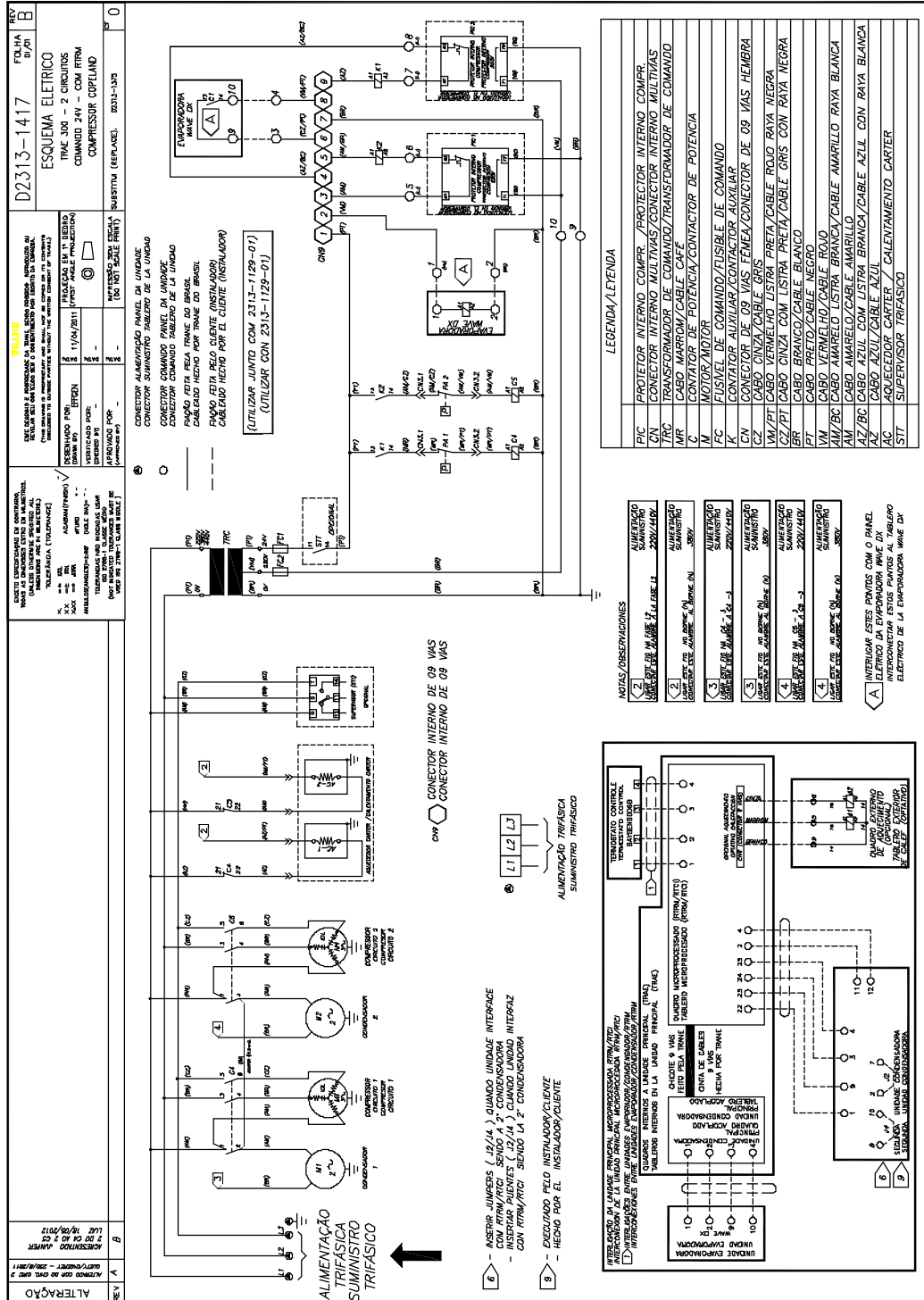

Wiring Diagram

TRAE-RTRM

Fig. VII-35b - Wiring Diagram of strength and command TRAE 200/250 - 1 circuit - With RTRM

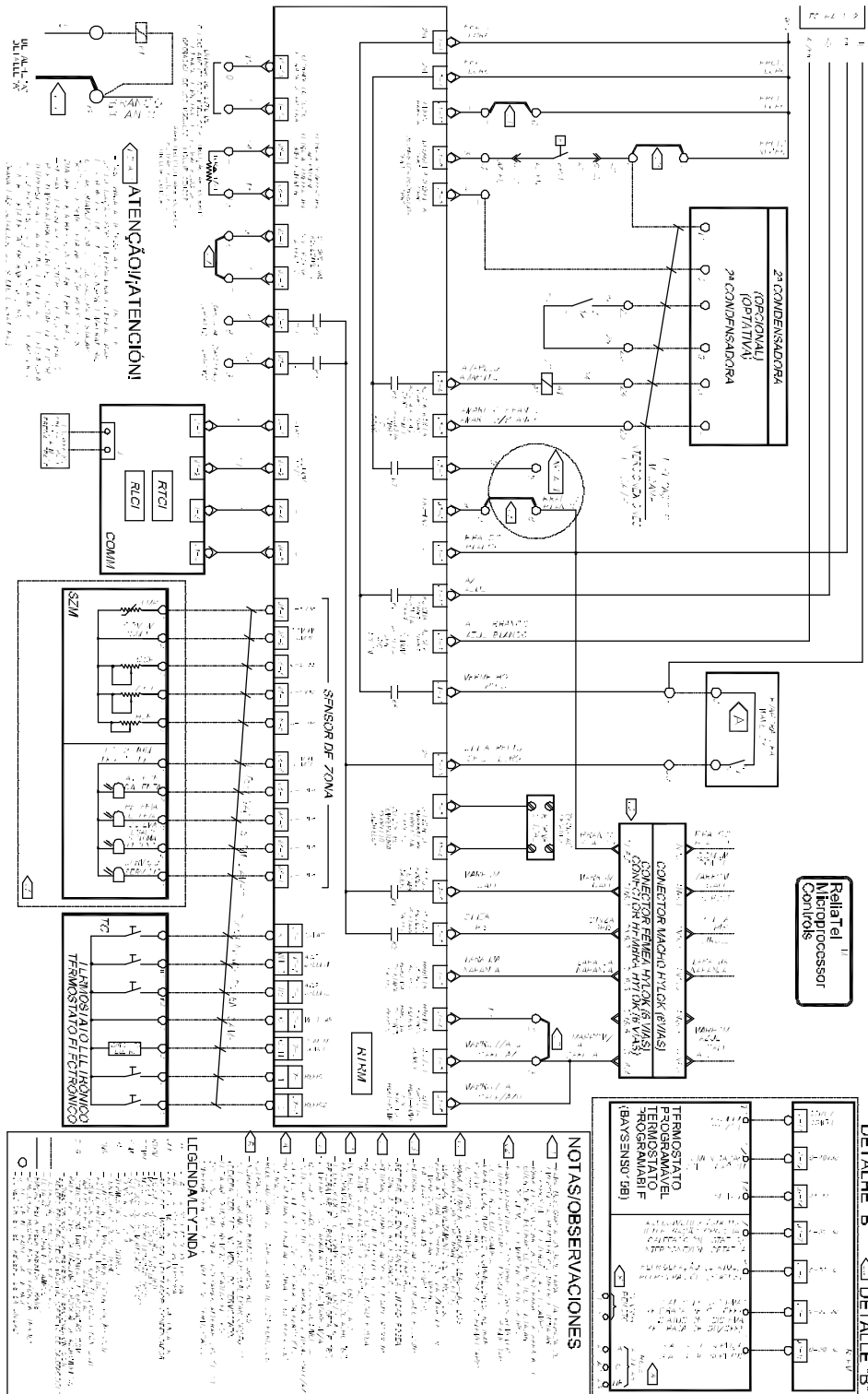

Wiring Diagram Layout

TRAE

Fig. VII-37 - Layout - TRAE 200/250.

D1539-2083-01B

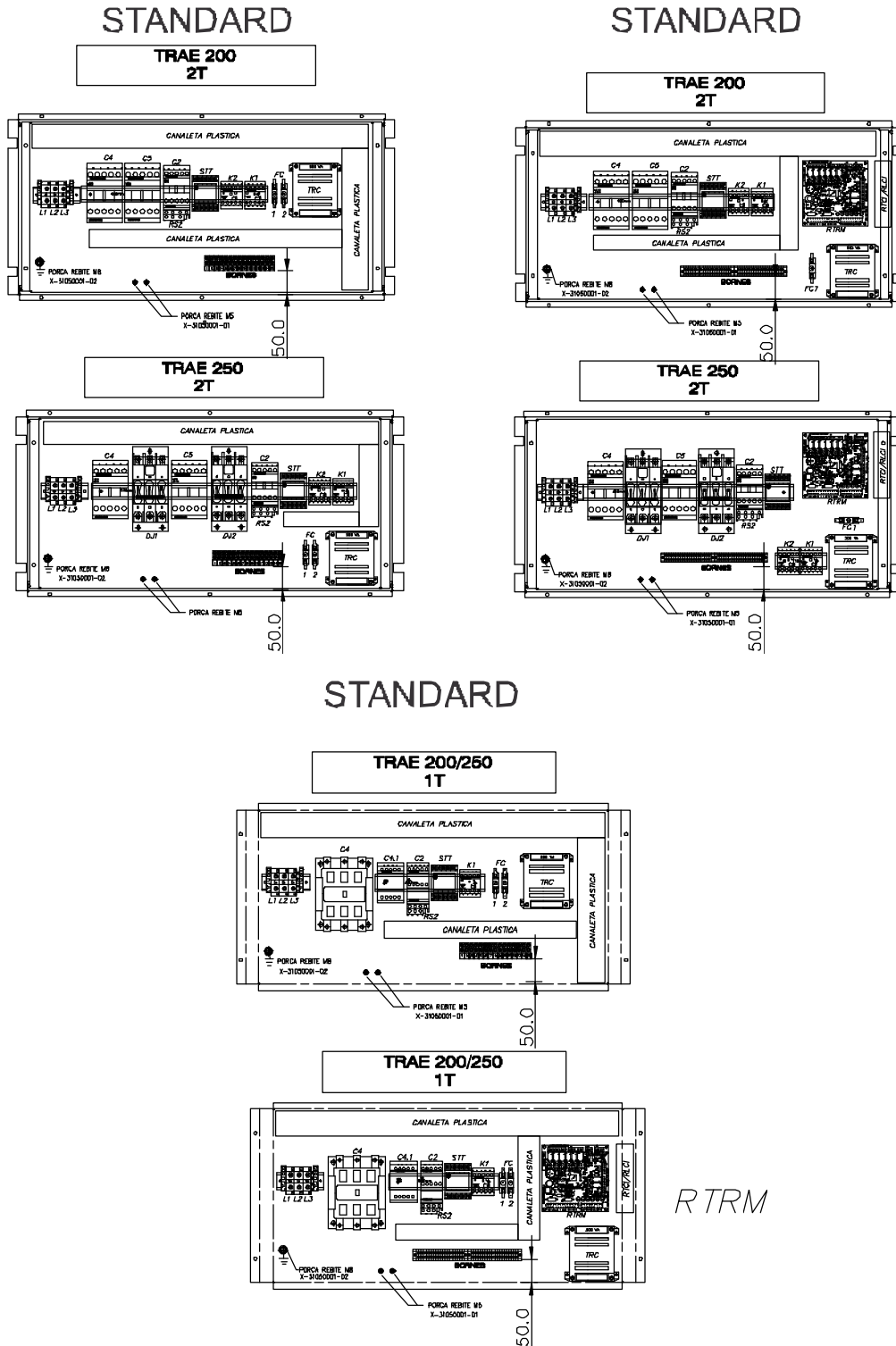

Wiring Diagram Layout

TRAE

Fig. VII-38 - Layout - TRAE 200/250 - 2 circuits.

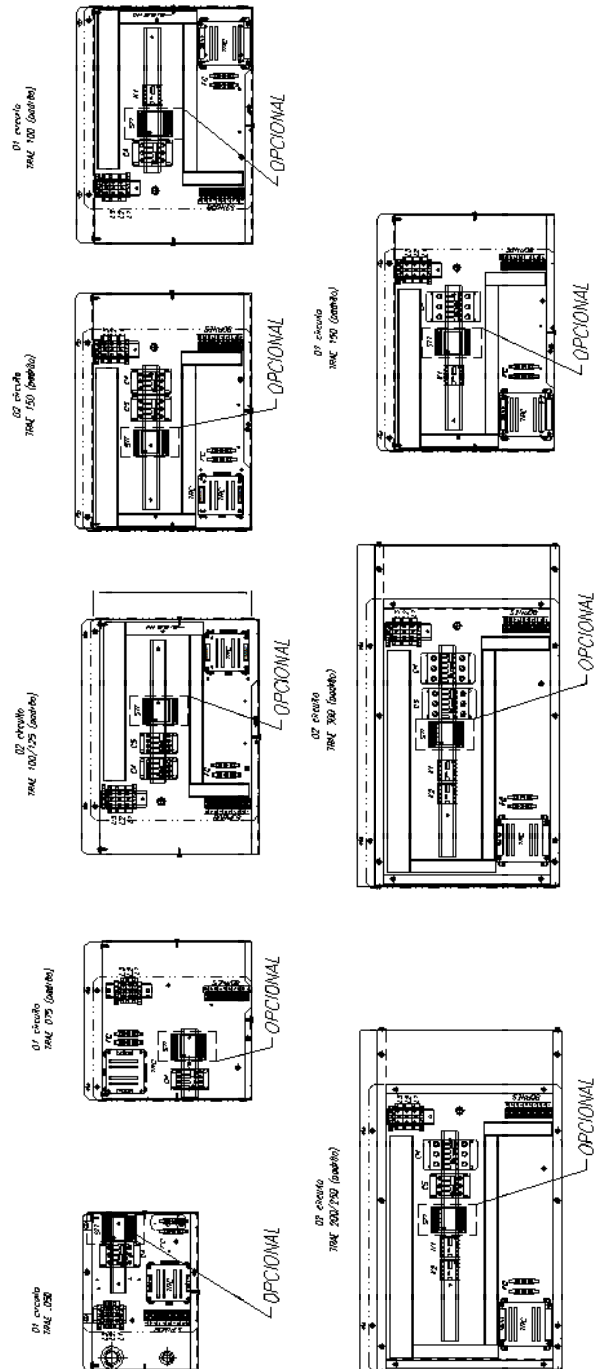

Wiring Diagram Layout

TRAE

Fig. VII-39 - Layout - TRAE 200/250 - 1 circuit.

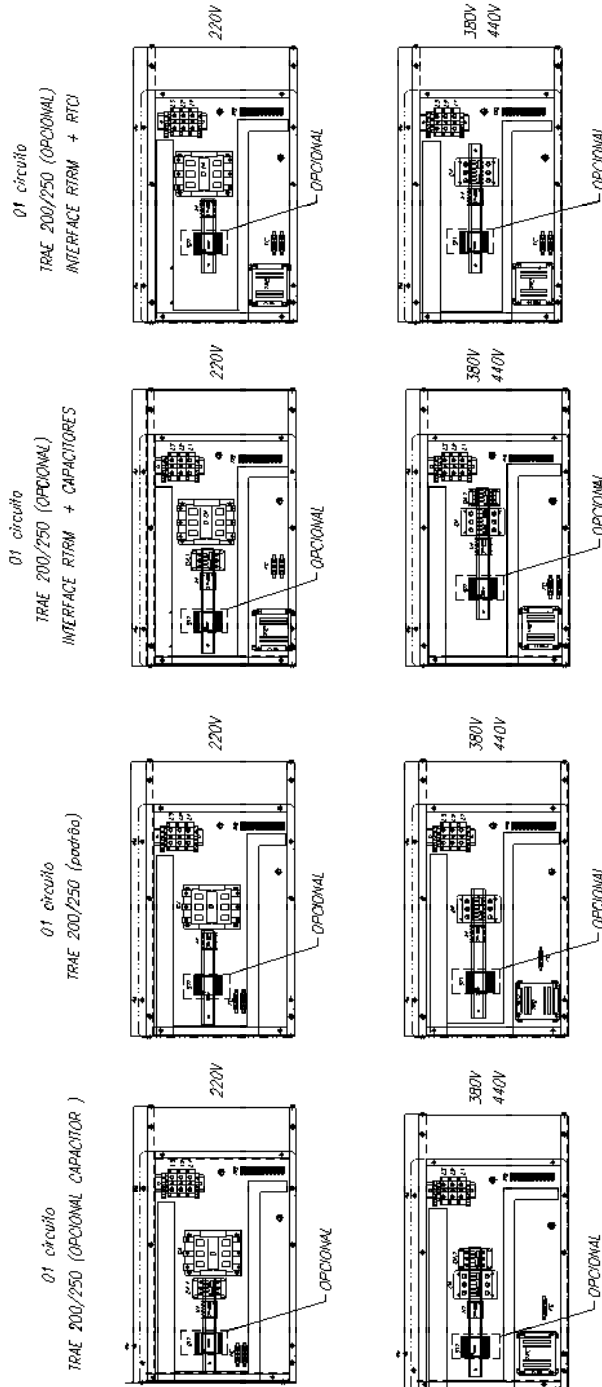

Wiring Diagram

TRCE

Fig. VII-39 - Wiring Diagram TRCE -020/030/050/075 - 1 circuit and 100/125/150 - 2 circuits

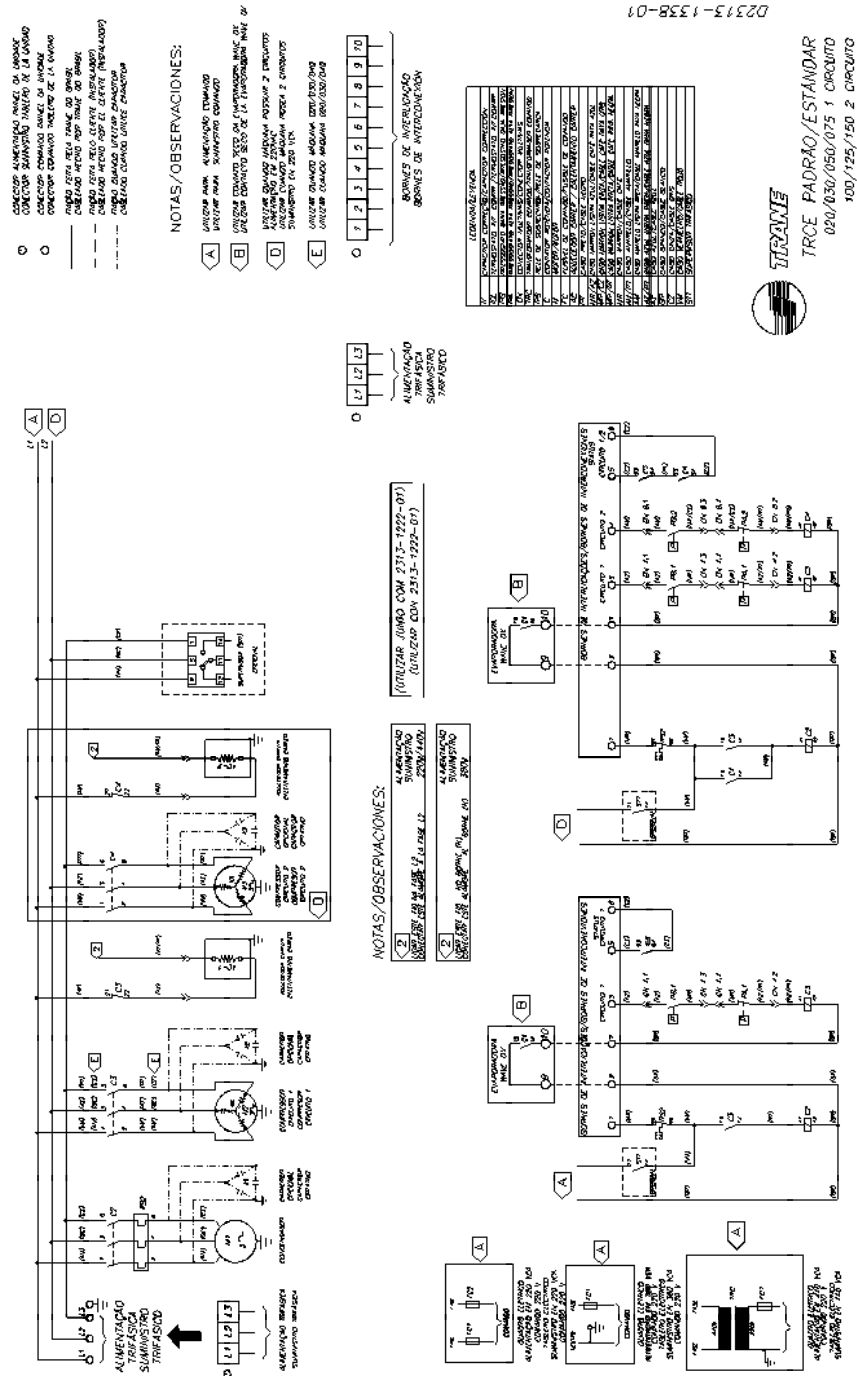

02313-1338-01

TRANE
TRCE PADRÃO/ESTÁNDAR
020/030/050/075 1 CIRCUITO
100/125/150 2 CIRCUITO

Wiring Diagram

TRCE - RTRM

Fig. VII-48 - Wiring Diagram TRCE (RTRM) - 150 - 1 circuit.

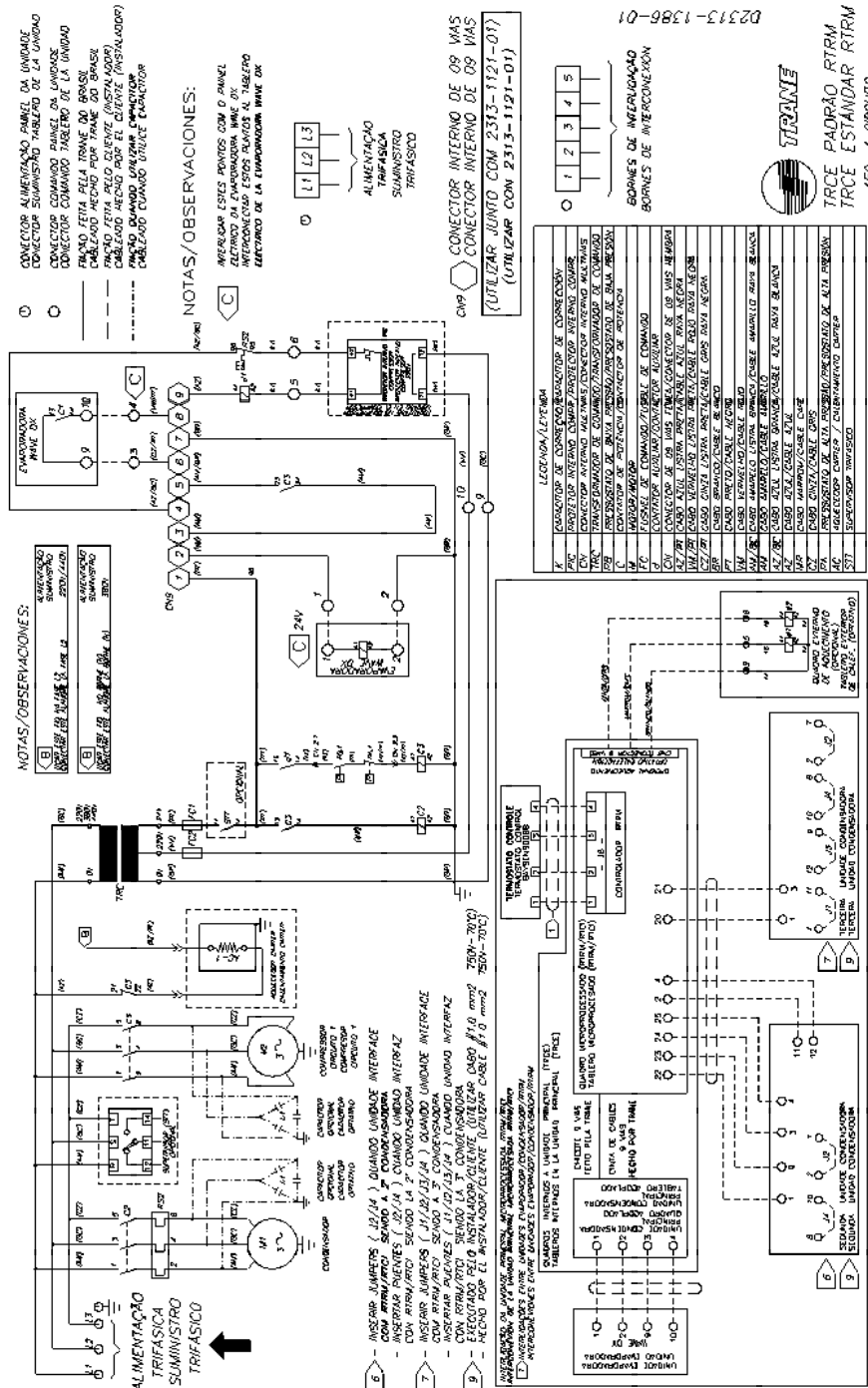

Wiring Diagram

TRCE - RTRM

Fig. VII-54 - Wiring Diagram TRCE150 1 CIRCUIT Standard

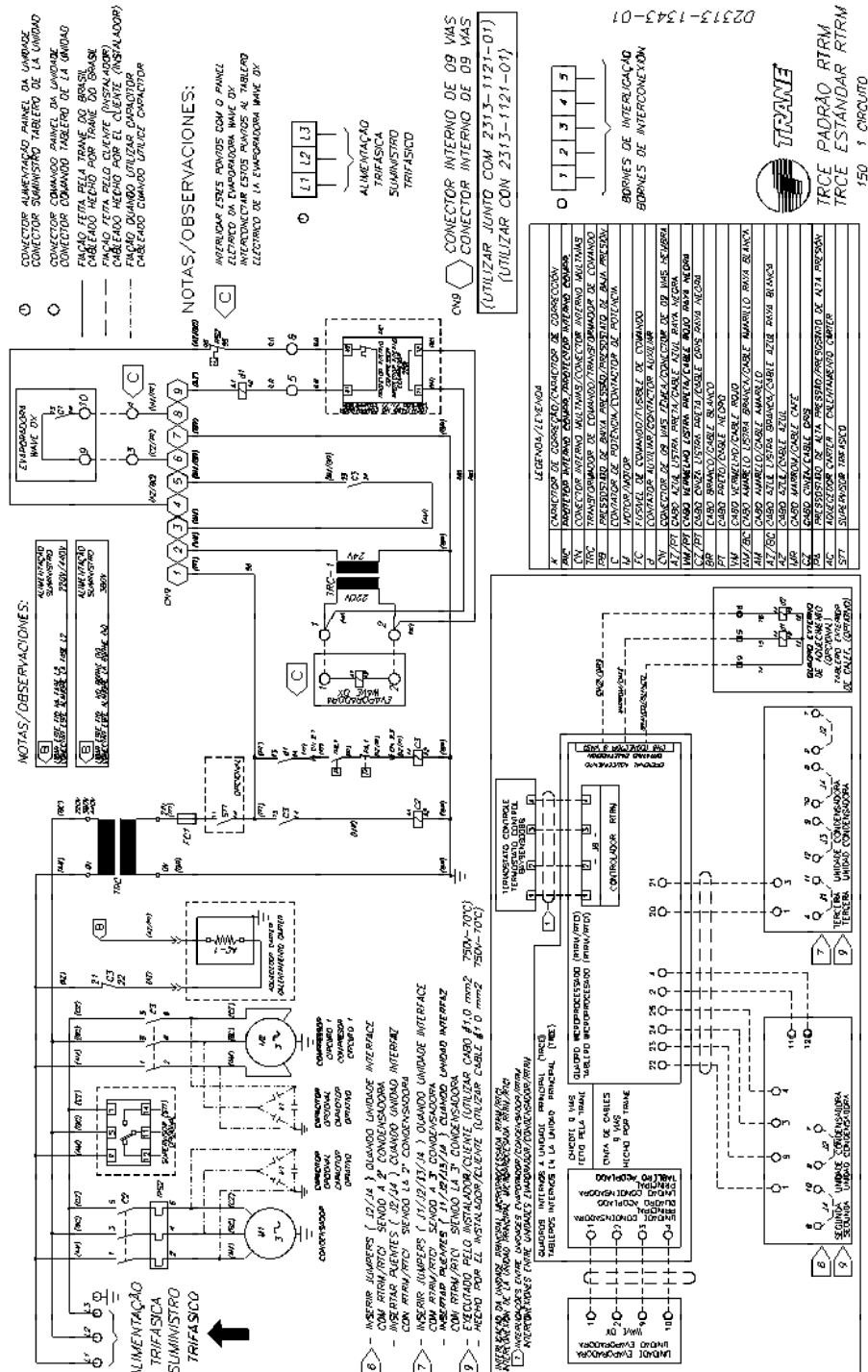

Wiring Diagram Layout

TRCE-RTRM

Fig. VII-55 - Layout - TRCE - Standard.

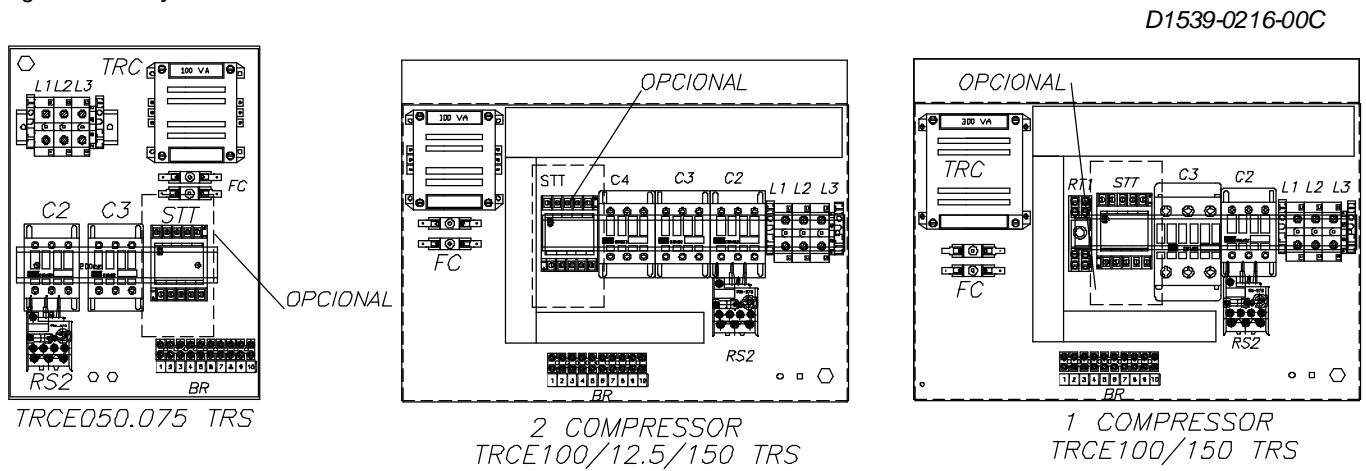
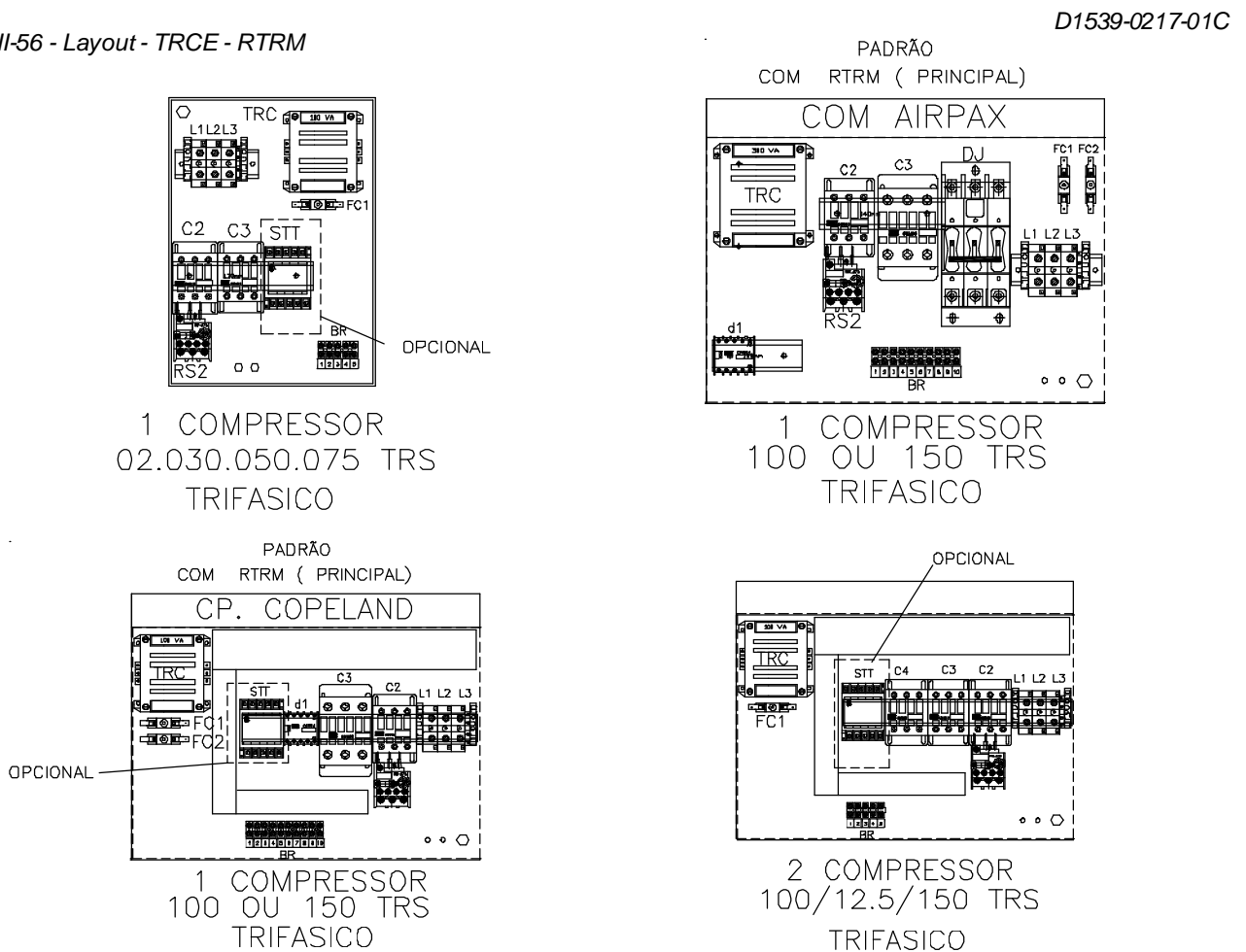
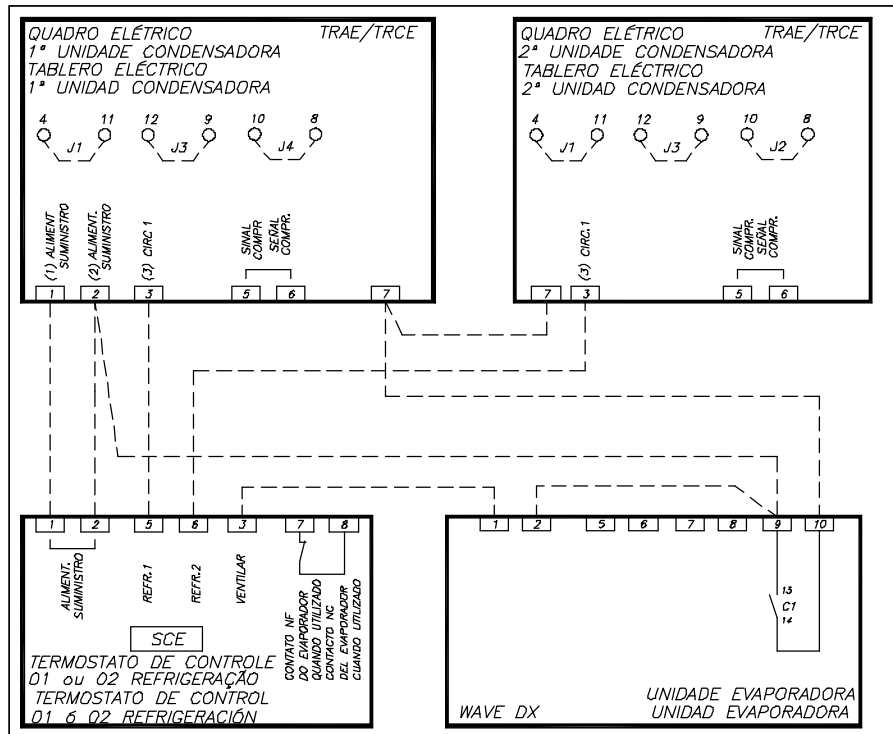
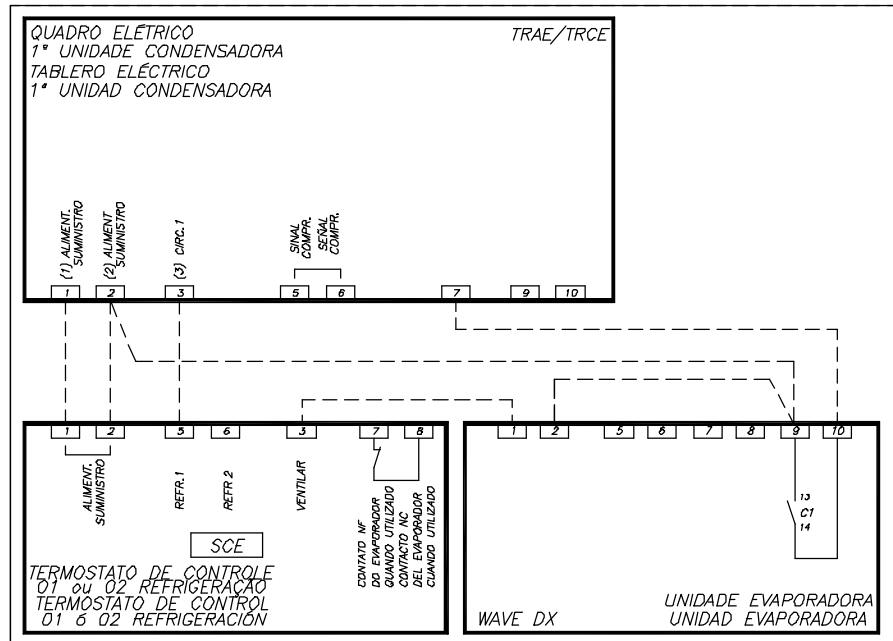

Fig. VII-56 - Layout - TRCE - RTRM



Wiring Diagram

Fig. VII-57 - Wiring Diagram **Evaporator Unit + Condensing Unit (TRAE/TRCE)**



Wiring Diagram

Fig. VII-58 - Wiring Diagram Evaporator Unit + Condensing Unit (TRAE/TRCE)

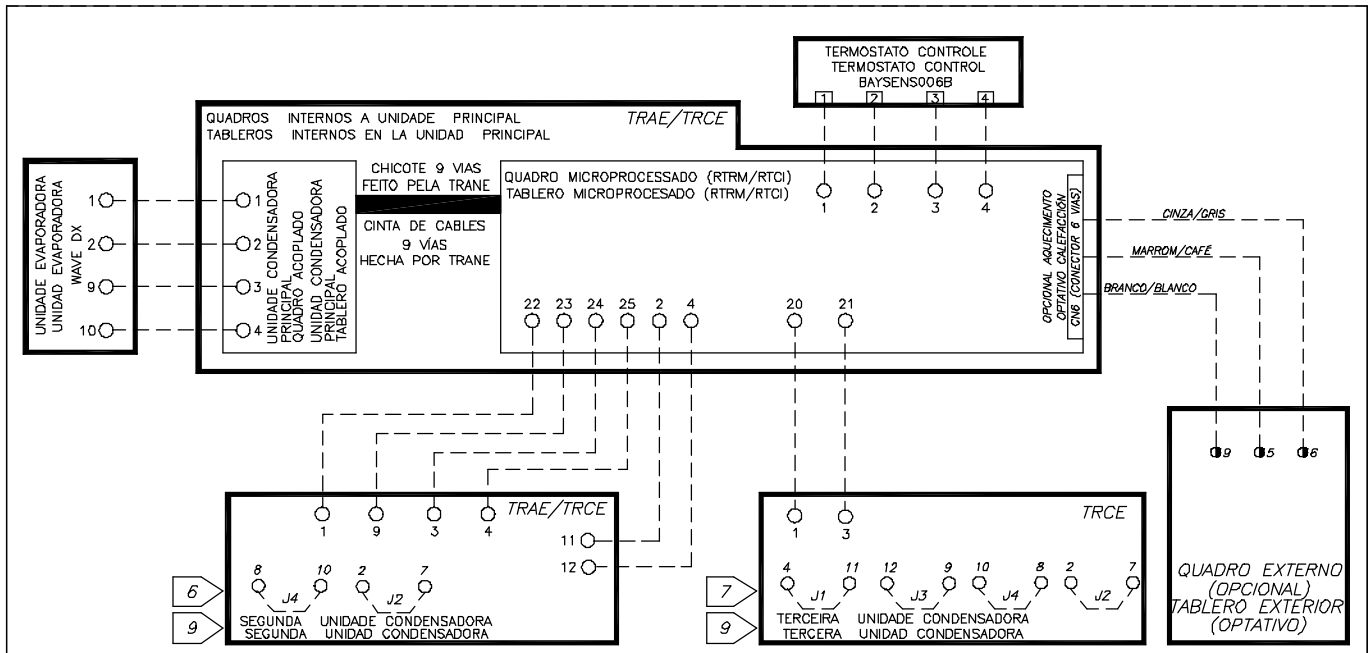
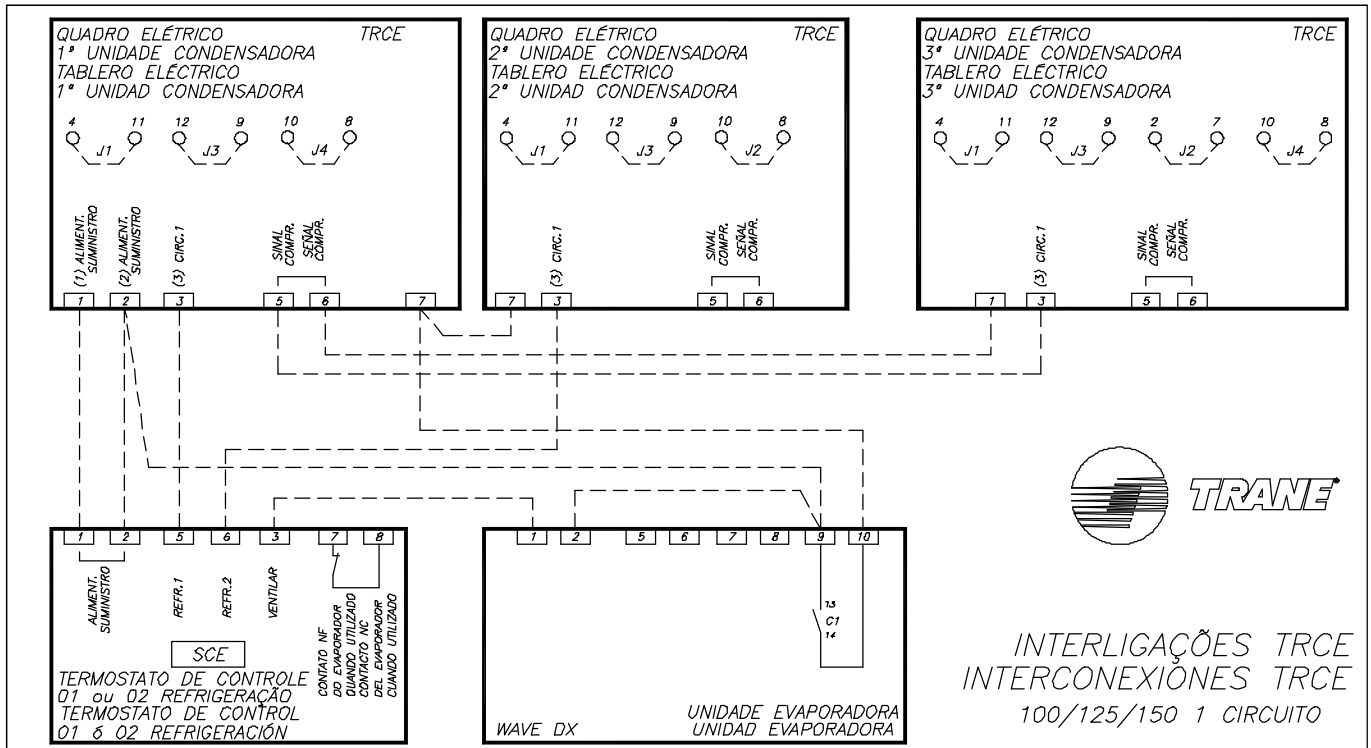

Fig. VII-59 - Wiring Diagram Evaporator Unit + Condensing Unit (TRCE)



Dimensional Data

TRAE

Fig. VIII-03 - Dimensions - Condensing Units TRAE 100 - 1 circuit

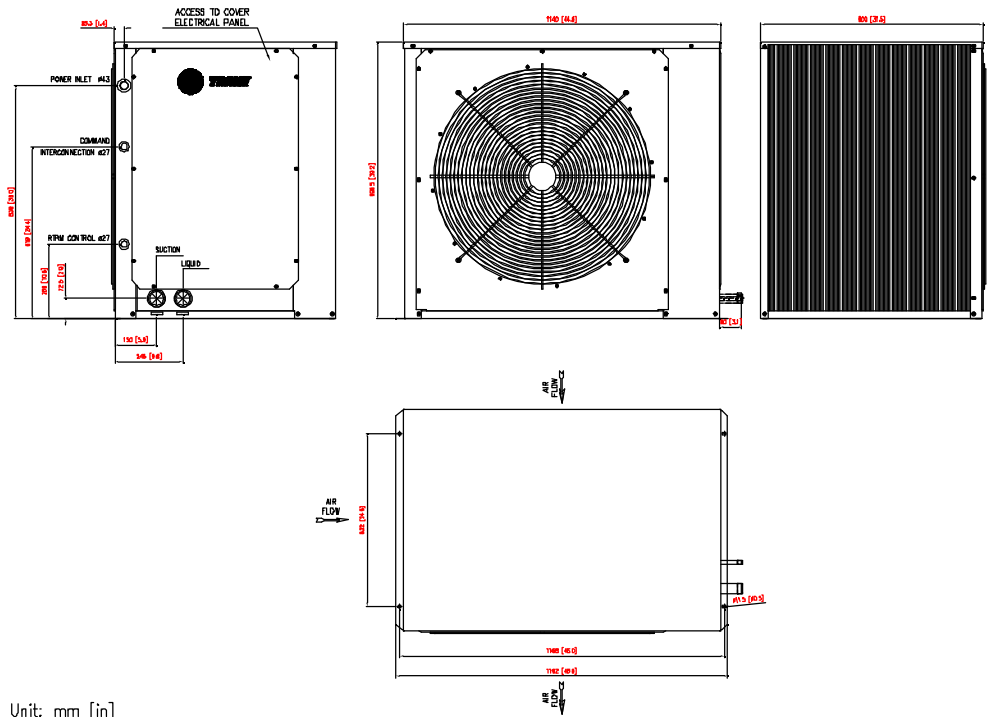

Unit: mm [in]

Fig. VIII-04 - Dimensions - Condensing Units TRAE 100 - 2 circuits

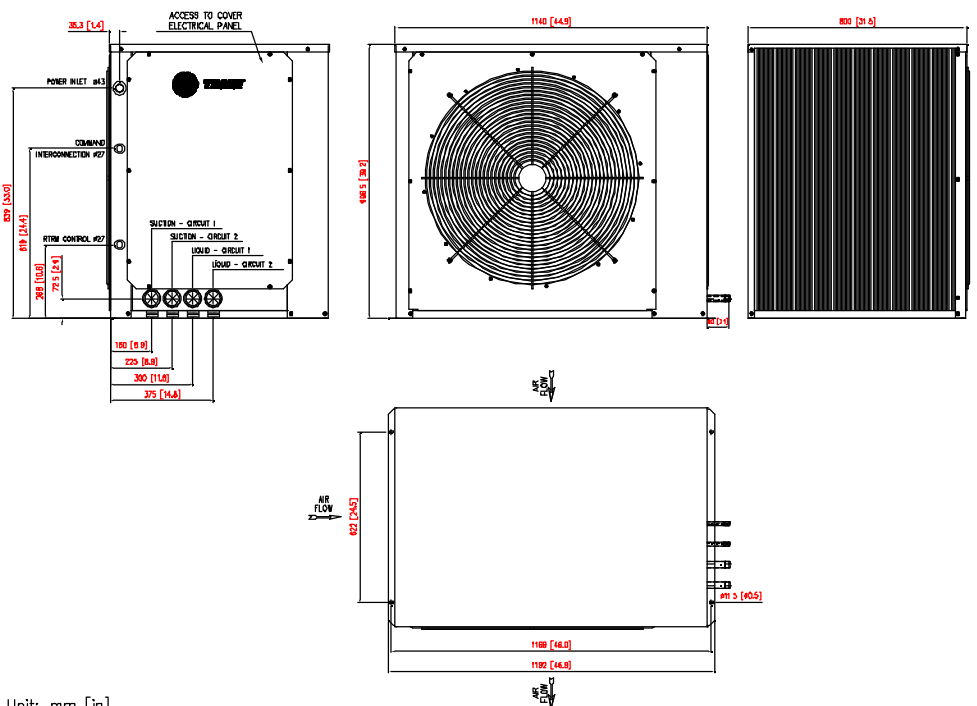

Unit: mm [in]

Dimensional Data

TRAE

Fig. VIII-05 - Dimensions - Condensing Units TRAE 125

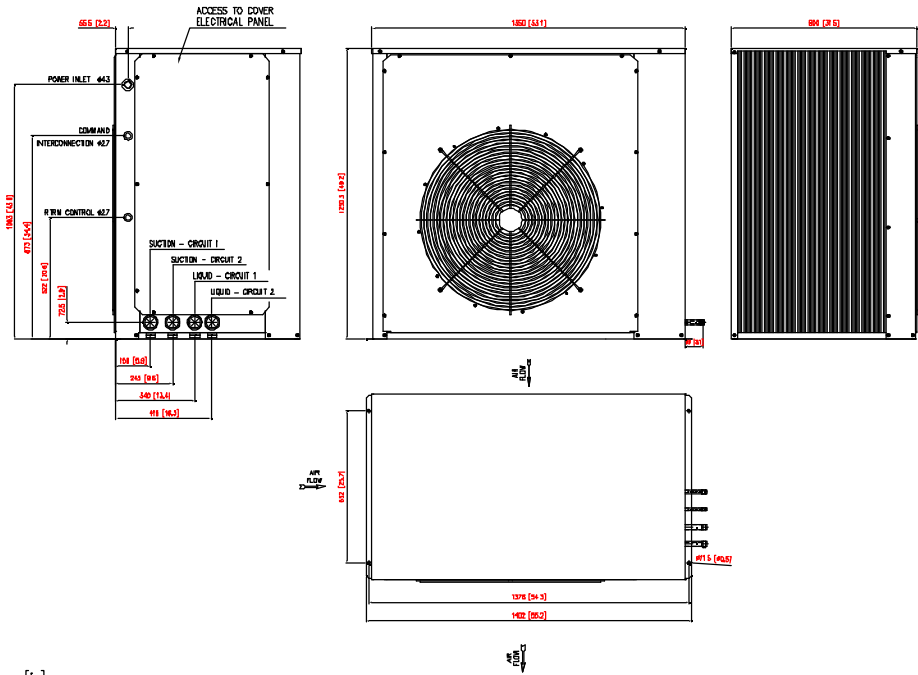
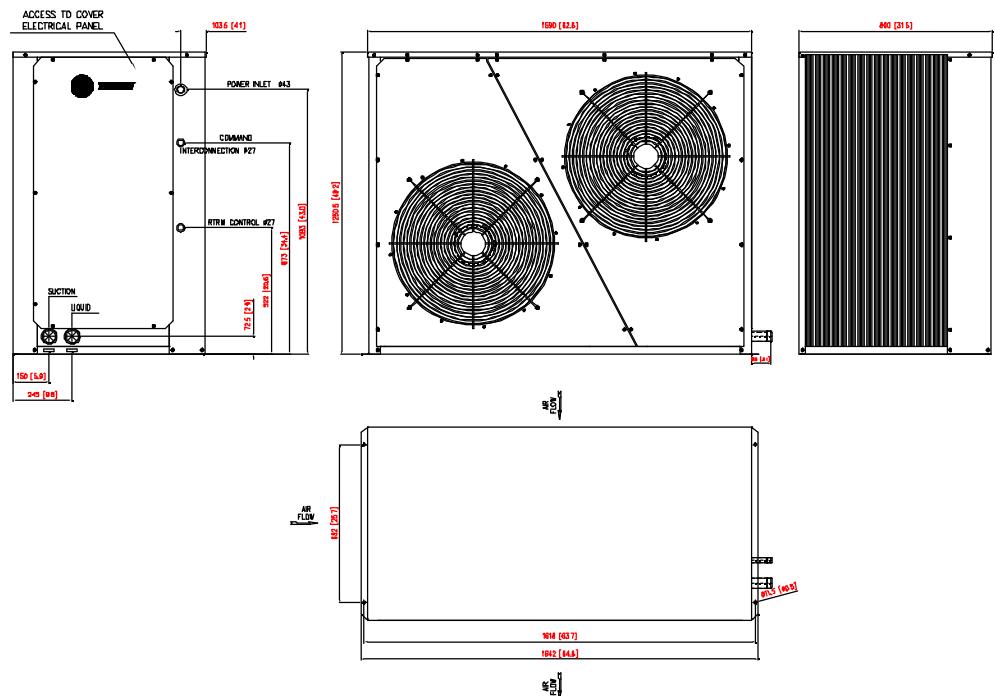

Fig. VIII-06 - Dimensions - Condensing Units TRAE 150 - 1 circuit



Dimensional Data

TRAE

Fig. VIII-07 - Dimensions - Condensing Units TRAE 150 - 2 circuits

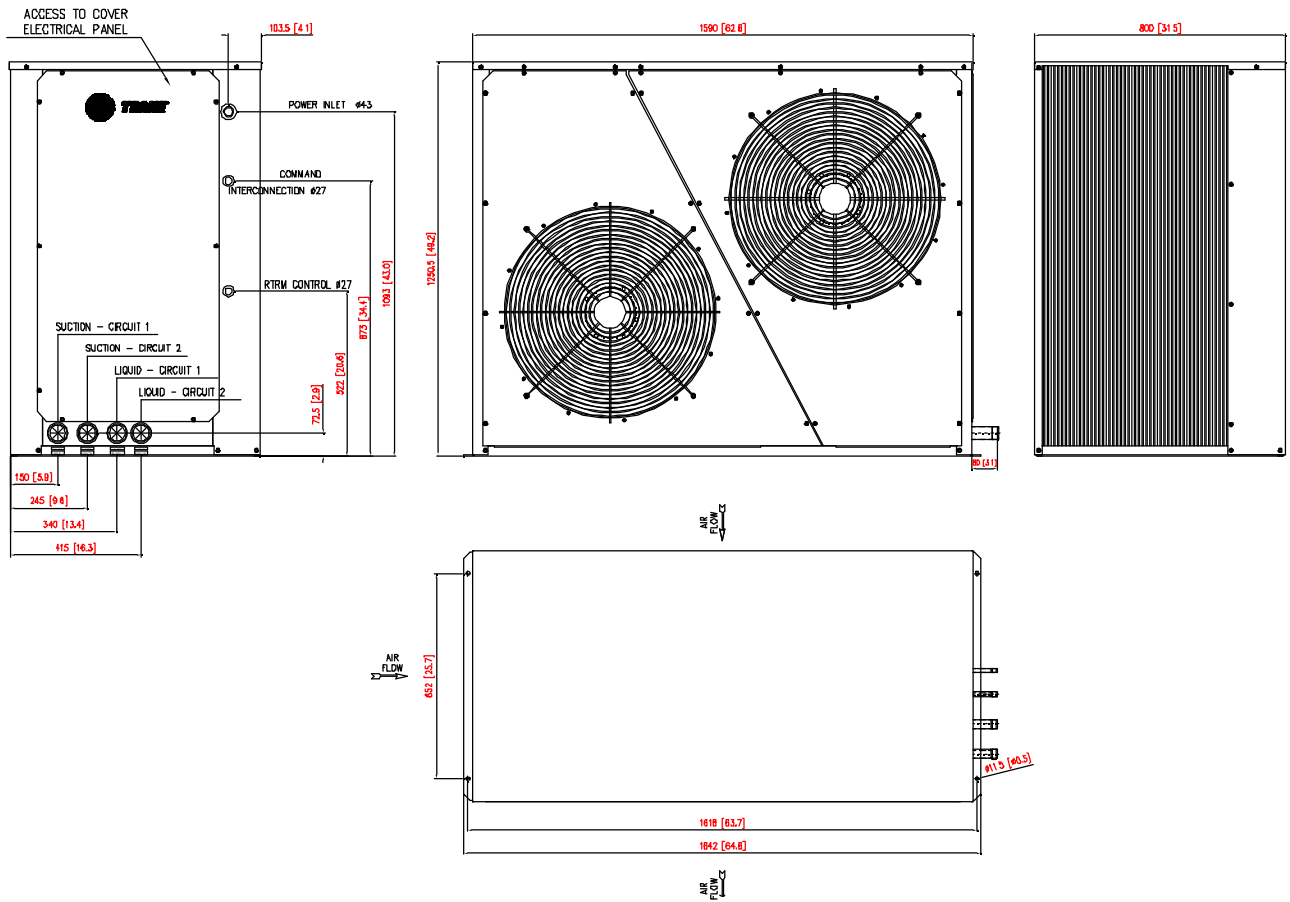

Unit: mm [in]

Dimensional Data

Fig. VIII-09 - Dimensions - Condensing Units TRAE 200 - 1 Circuit

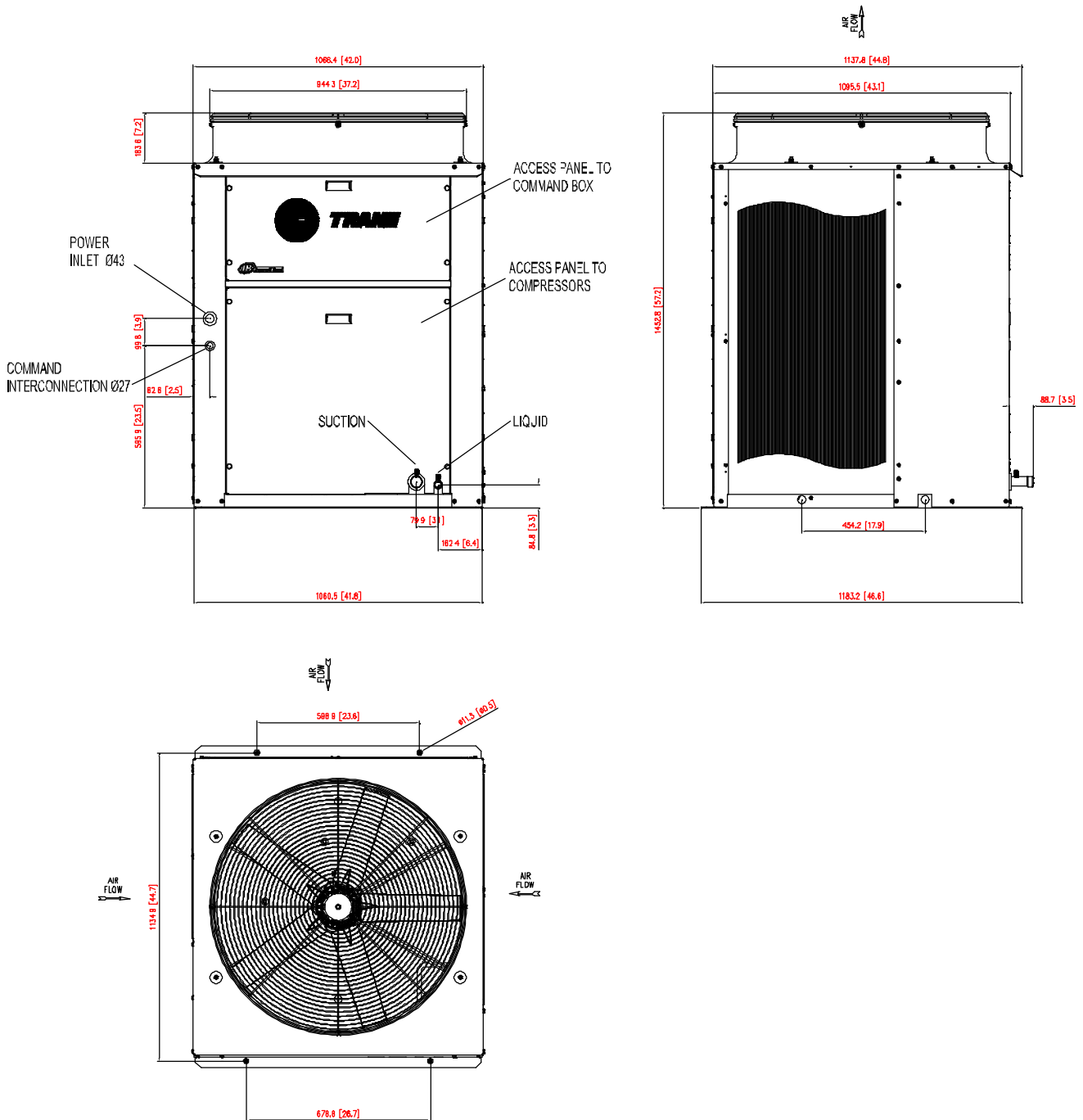

Unit: mm [in]

Dimensional Data

TRAE

Fig. VIII-10 - Dimensions - Condensing Units TRAE 200 - 2 Circuits

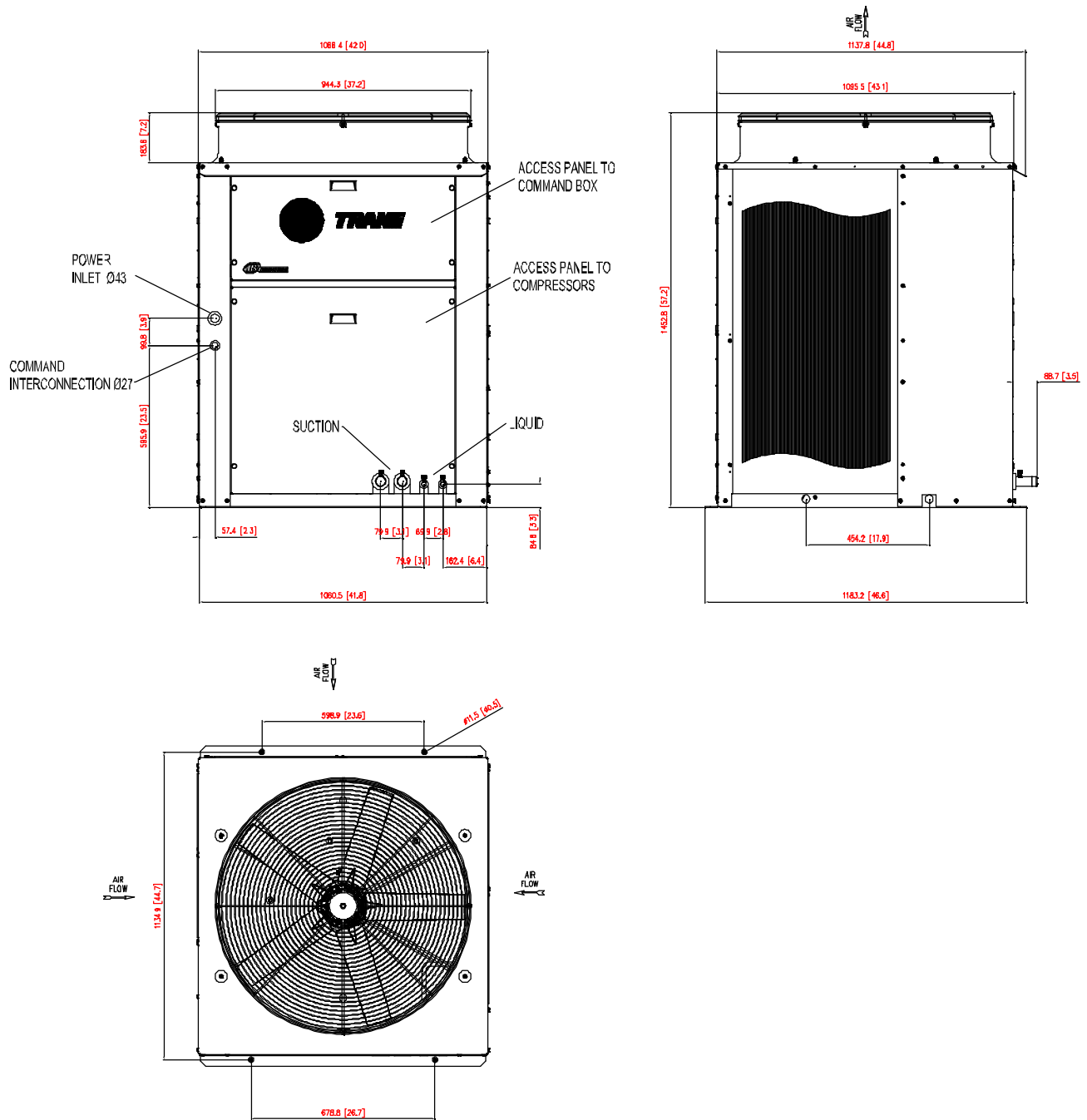

Unit: mm [in]

Dimensional Data

TRAE

Fig. VIII-11 - Dimensions - Condensing Units TRAE 250 - 1 Circuit

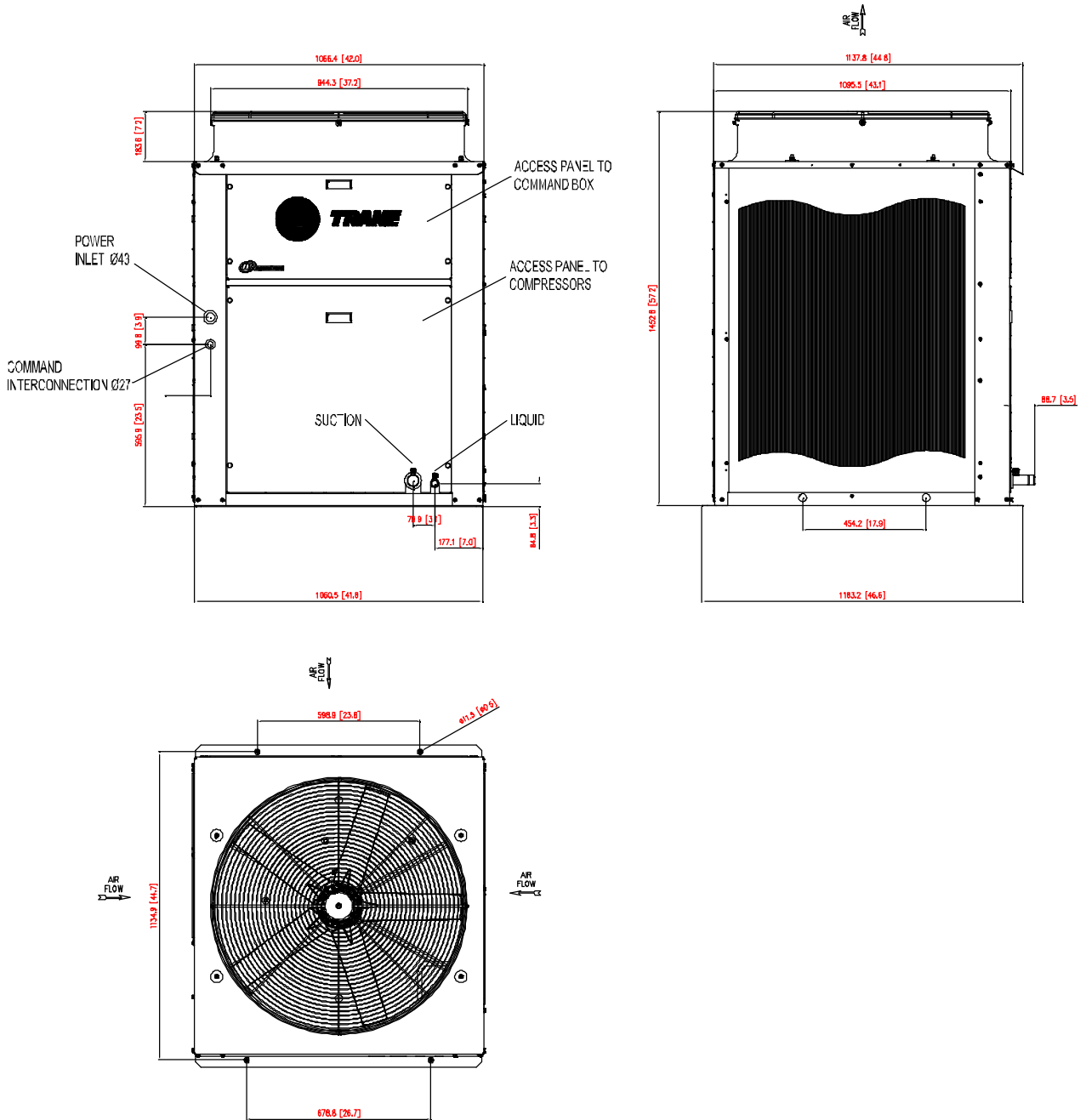

Unit: mm [in]

Dimensional Data

TRAE

Fig. VIII-12 - Dimensions - Condensing Units TRAE 250 - 2 Circuits

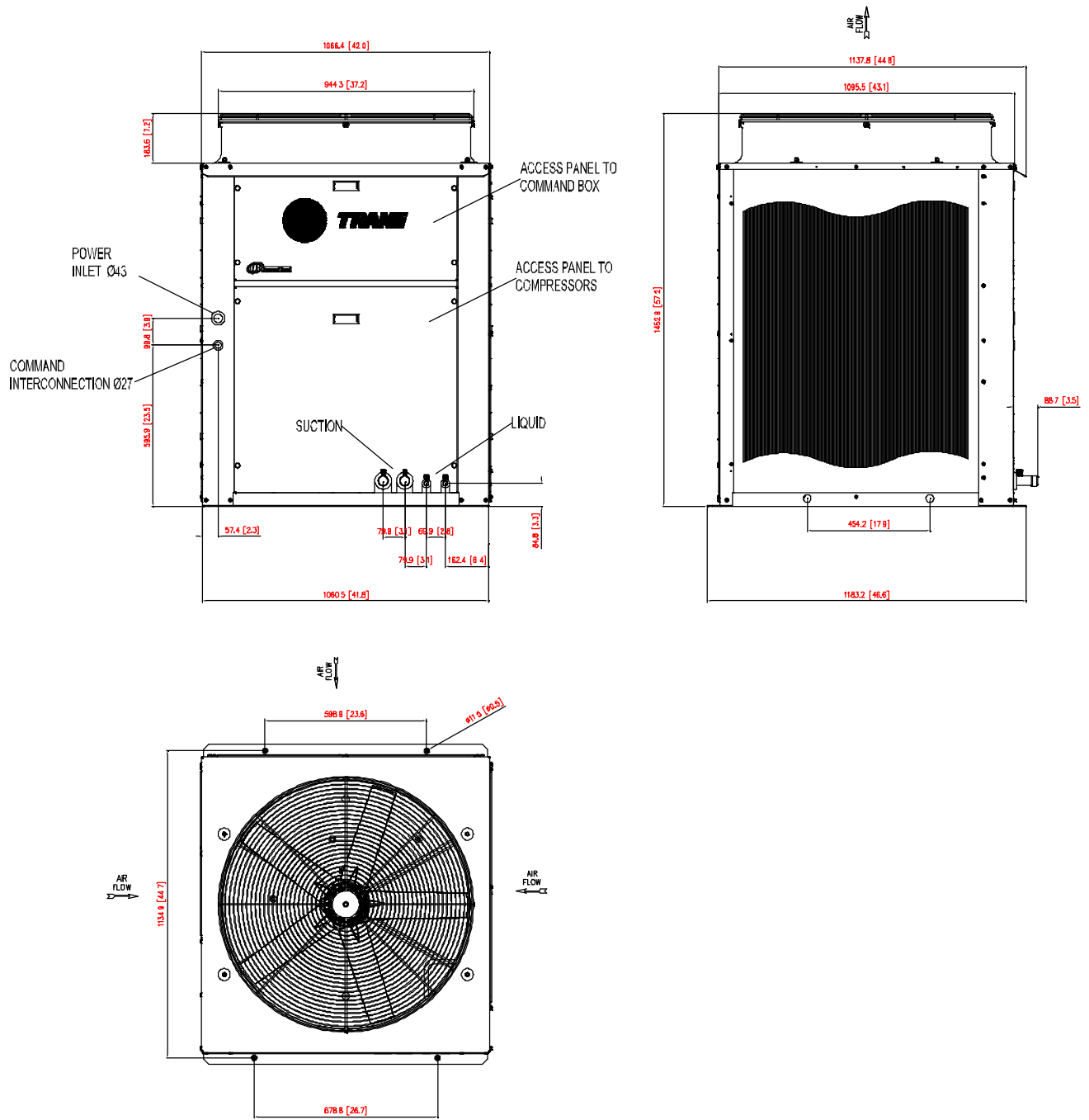

Unit: mm [in]

Dimensional Data

Fig. VIII-13 - Dimensions - Condensing Units TRAE 300 - 2 Circuits

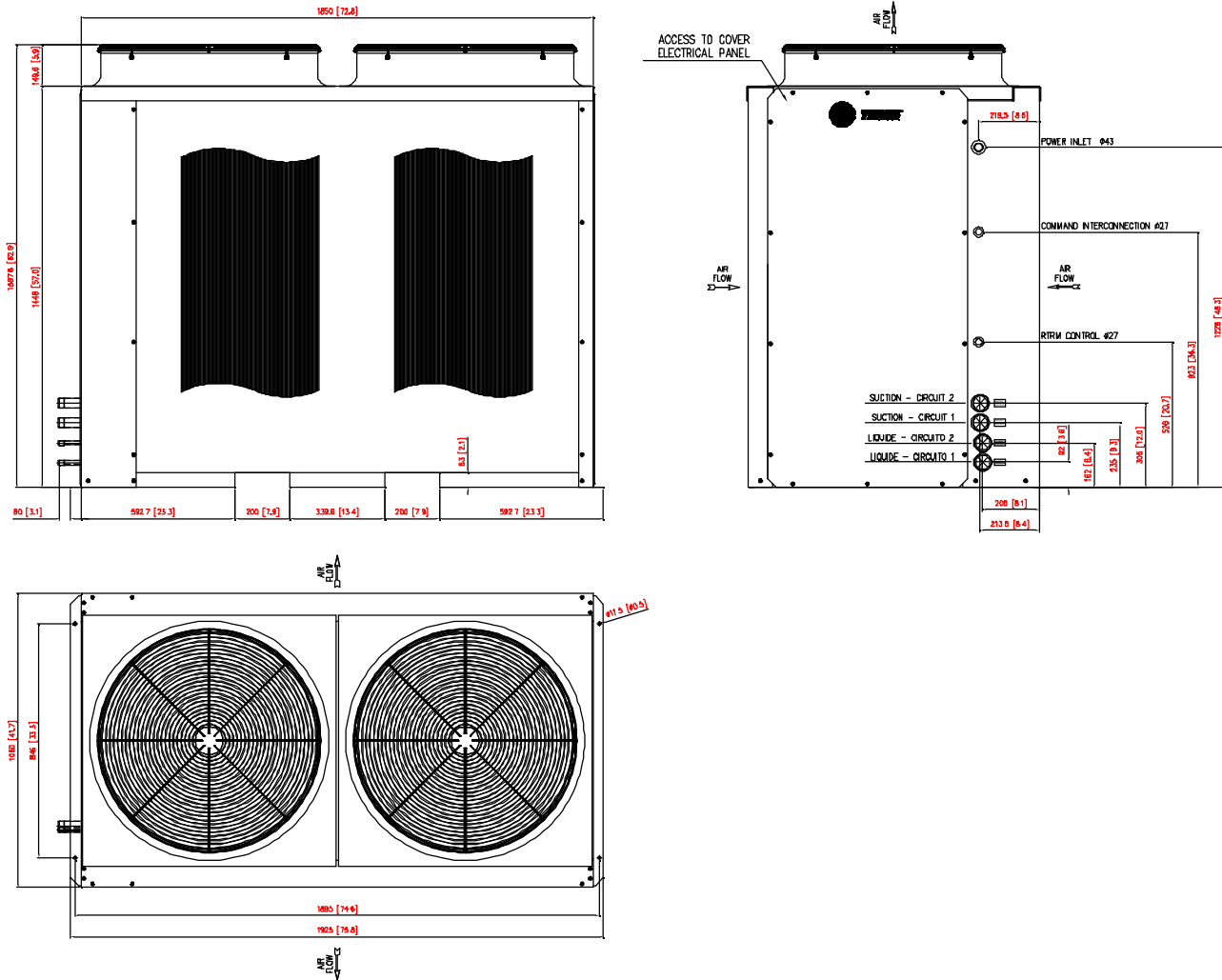

Unit: mm [in]

Dimensional Data

CRCB

Fig.VIII-14- Dimensions CRCB 050 to 150.

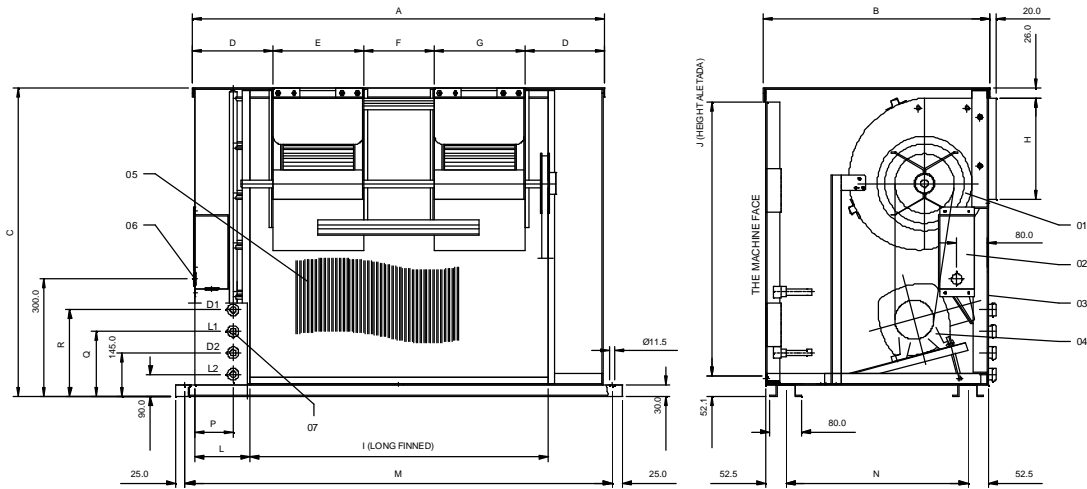

- 1 Double-suction centrifugal fan (evaporator)
- 2 Terminal box
- 3 Maintenance cover
- 4 Three-phase electrical motor
- 5 Condensing coil (Micro-channel)
- 6 Cable passage Ø27 for power inlet
- 7 Refrigeration connections (single position)

Tab.VIII-01 - Dimensions CRCB 050 to 150.

MODEL	A	B	C	D	E	F	G	H	I	J	L	M	N	P	Q	R	ØL1	ØD1	ØL2	ØD2
050	987	631	890	295.5	396	-	-	341	762	711	110	1029	521	132	-	-	1/2"	5/8"	-	-
075	1241	631	890	422.5	396	-	-	341	1016	816.5	110	1283	521	132	-	-	1/2"	3/4"	-	-
100 C/2	1341	631	941	222.5	333	230	333	289	1143	863.5	97	1383	521	159	200	255	1/2"	5/8"	1/2"	5/8"
125 C/2	1646	714	1018	299.5	396	255	396	341	1473	940	84	1688	604	236	200	255	1/2"	3/4"	1/2"	5/8"
150 C/2	1646	714	1247	299.5	396	255	396	341	1473	1168.5	84	1688	604	236	200	255	1/2"	3/4"	1/2"	3/4"

Note:
Unit:mm

Dimensional Data

CRCE/TRCE

Tab. VIII-02 - Dimensions - TRCE/CRCE

	Modelo				
Cota	050	075	100	125	150
A	922	1146	1420	1640	1640
B	1373	1474	1525	1600	1829
C	560	560	560	560	560
D	341	341	290	341	341
E	374	480	402	432	432
F	386	386	326	386	386
G	---	---	230	255	255
H	778	879	930	1005	1234
K	813	914	965	1040	1269
L	560	560	560	560	560

Fig. VIII-16 - Dimensions - TRCE/CRCE

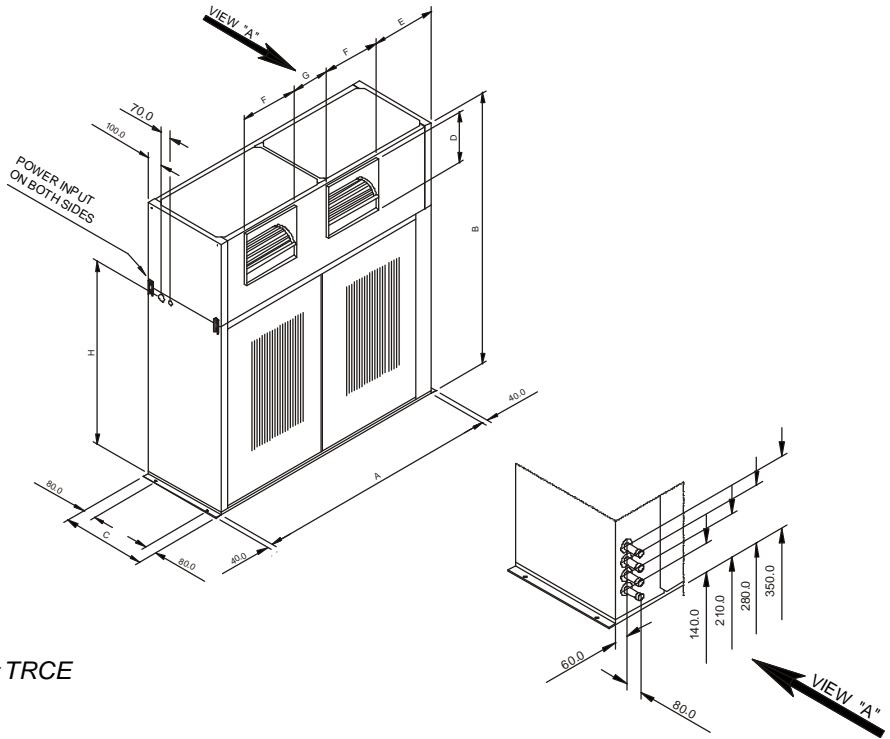
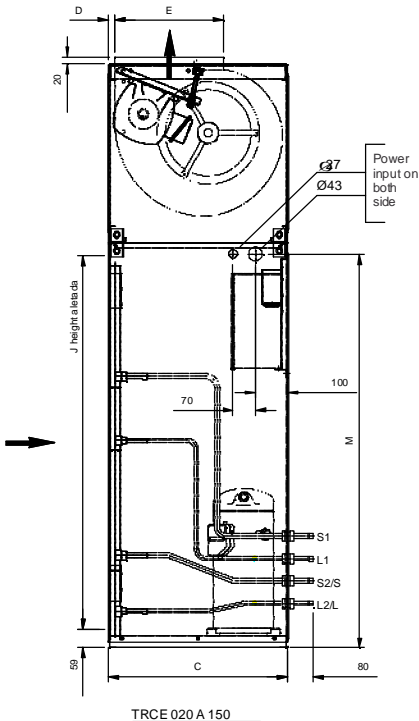

Fig. VIII-15 - Connections - condensing unit TRCE



Tab. VIII-03 - Dimensions - TRCE/CRCE

	Measures (mm)				
	C	D	E	J	M
50	560	20	341	711	778
75	560	20	341	813	879
Models TRCE					
100C/1	560	95	290	864	930
100C/2	560	20	341	940	1005
125C/1	560	20	341	1168	1234
150C/2	560	20	341	1168	1234

Tab. VIII-04 - Connection dimensions - TRCE

	Models TRCE							
	050	075	100C/1	100C/2	125C/1	125C/2	150C/1	150C/2
Connections (pol)								
S1	---	---	---	7/8"	---	1 1/8"	---	1 1/8"
L1	---	---	---	1/2"	---	1/2"	---	1/2"
S2/S	7/8"	1 1/8"	1 3/8"	7/8"	---	7/8"	1 5/8"	1 1/8"
L2/L	1/2"	1/2"	5/8"	1/2"	---	1/2"	7/8"	1/2"

Dimensional Data

Application Considerations TRAE / TRCE

Fig. VIII-17 - Clearances required for Maintenance and Air Circulation - TRAE

Suggested clearances TRAE 050 to 150 - Horizontal Discharge

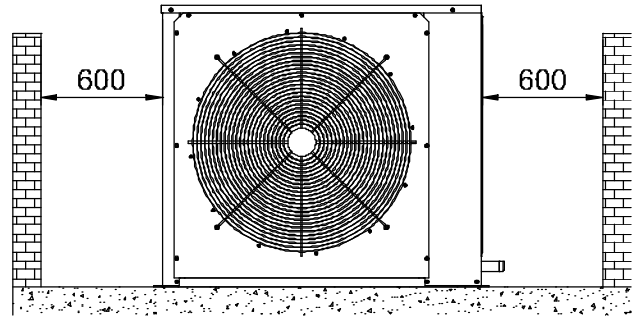
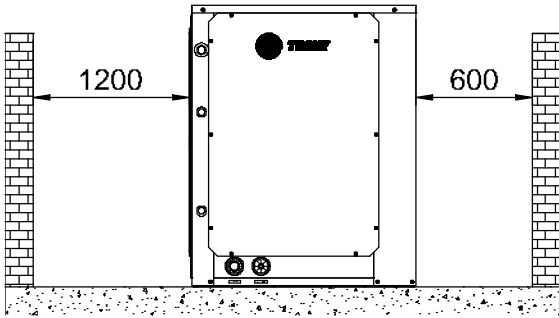

Suggested clearances TRAE 200 to 300 - Vertical Discharge

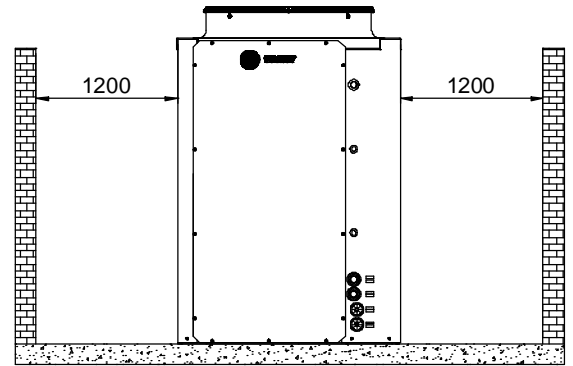
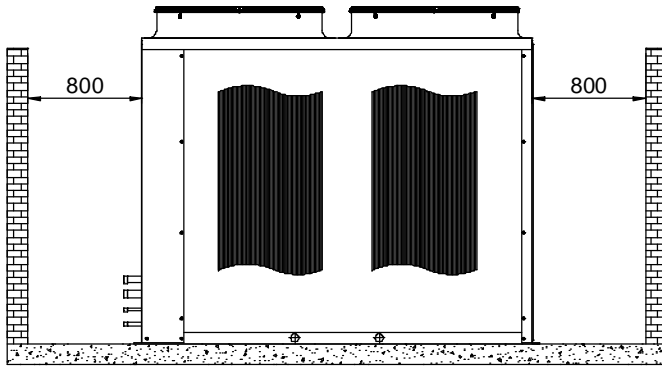
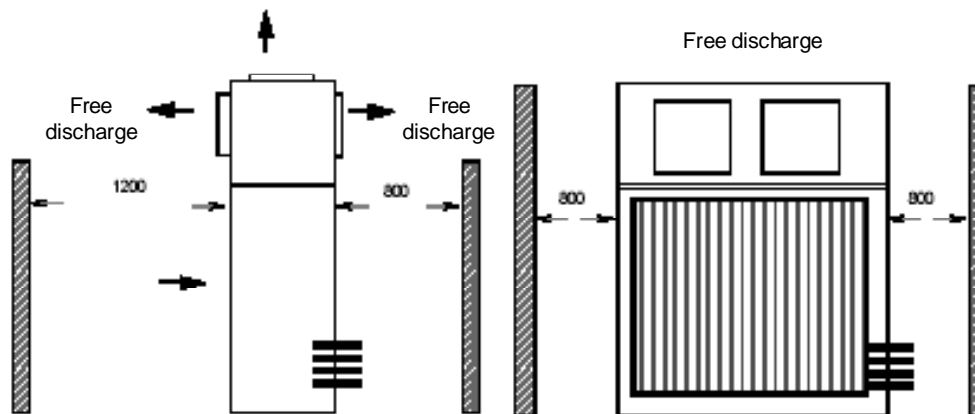

Fig. VIII-18 - Suggested Clearances for Maintenance and Air Circulation - Condensing Unit TRCE 050 to 150.



Unit: mm



IX-Standard Conversion Table

To convert from:	To:	Multiply By:	To convert from:	To:	Multiply By:
Length			Velocity		
Feet (ft)	meters (m)	0,30481	Feet per minute (ft/min)	meters per second (m/s)	0,00508
Inche (in)	millimeters (mm)	25,4	Feet per second (ft/s)	meters per second (m/s)	0,3048
Area			Energy, Power and Capacity		
Square feet (ft ²)	square meters(m ²)	0,93	British Thermal Units (BTU)	Kilowatt (kW)	0,000293
Square inche(in ²)	square millimeters(mm ²)	645,2	British Thermal Units (BTU)	Kilocalorie (kcal)	0,252
			Tons (refrig. Effect)	Kilowatt (kW)	3,516
Volume			Tons (refrig. Effect)	Kilocalorie per hour (kcal/h)	3,024
Cubic feet (ft ³)	cubic meters(m ³)	0,0283	Horsepower (HP)	Kilowatt (kW)	0,7457
Cubic Inche (in ³)	cubic millimeters (mm ³)	16387			
Gallons (gal)	litres (L)	3,785			
Gallons (gal)	cubic meters (m ³)	0,003785			
Flow			Pressão		
Cubic feet / min (cfm)	cubic meters / second (m ³ /s)	0,000472	Feet of water (ft.H ₂ O)	Pascal (Pa)	2990
Cubic feet / min (cfm)	cubic meters / hour (m ³ /h)	1,69884	Inches os water (in.H ₂ O)	Pascal (Pa)	249
Gallons / min (GPM)	cubic meters / hour (m ³ /h)	0,2271	Pounds per square inch (PSI)	Pascal (Pa)	6895
Gallons / min (GPM)	litres / second (L/s)	0,06308	Pounds per square inch (PSI)	Bar ou kg/cm ²	6,895 x 10 ⁻²
			Peso		
			Ounces (oz)	Kilograms (kg)	0,02835
			Pounds (lbs)	Kilograms (kg)	0,4536

Temperature		
°C	CoU F	°F
-40,0	-40	40
-39,4	-39	38,2
-38,9	-38	36,4
-38,3	-37	34,6
-37,8	-36	32,8
-37,2	-35	31
-36,7	-34	29,2
-36,1	-33	27,4
-35,6	-32	25,6
-35,0	-31	23,8
-34,4	-30	22
-33,9	-29	20,2
-33,3	-28	18,4
-32,8	-27	16,6
-32,2	-26	14,8
-31,7	-25	13
-31,1	-24	11,2
-30,6	-23	9,4
-30,0	-22	7,6
-29,4	-21	5,8
-28,9	-20	4
-28,3	-19	2,2
-27,8	-18	0,4
-27,2	-17	1,4
-26,7	-16	3,2
-26,1	-15	5
-25,6	-14	6,8
-25,0	-13	8,6
-24,4	-12	10,4
-23,9	-11	12,2
-23,3	-10	14
-22,8	-9	15,8
-22,2	-8	17,6
-21,7	-7	19,4
-21,1	-6	21,2
-20,6	-5	23
-20,0	-4	24,8
-19,4	-3	26,6
-18,9	-2	28,4
-18,3	-1	30,2
-17,8	0	32
-17,2	1	33,8
-16,7	2	35,6
-16,1	3	37,4
-15,6	4	39,2

Temperature		
°C	CoU F	°F
-15,0	5	41
-14,4	6	42,8
-13,9	7	44,6
-13,3	8	46,4
-12,8	9	48,2
-12,2	10	50
-11,7	11	51,8
-11,1	12	53,6
-10,6	13	55,4
-10,0	14	57,2
-9,4	15	59
-8,9	16	60,8
-8,3	17	62,6
-7,8	18	64,4
-7,2	19	66,2
-6,7	20	68
-6,1	21	69,8
-5,6	22	71,6
-5,0	23	73,4
-4,4	24	75,2
-3,9	25	77
-3,3	26	78,8
-2,8	27	80,6
-2,2	28	82,4
-1,7	29	84,2
-1,1	30	86
-0,6	31	87,8
0,0	32	89,6
0,6	33	91,4
1,1	34	93,2
1,7	35	95
2,2	36	96,8
2,8	37	98,6
3,3	38	100,4
3,9	39	102,2
4,4	40	104
5,0	41	105,8
5,6	42	107,6
6,1	43	109,4
6,7	44	111,2
7,2	45	113
7,8	46	114,8
8,3	47	116,6
8,9	48	118,4
9,4	49	120,2

Temperature		
°C	CoU F	°F
10,0	50	122
10,6	51	123,8
11,1	52	125,6
11,7	53	127,4
12,2	54	129,2
12,8	55	131
13,3	56	132,8
13,9	57	134,6
14,4	58	136,4
15,0	59	138,2
15,6	60	140
16,1	61	141,8
16,7	62	143,6
17,2	63	145,4
17,8	64	147,2
18,3	65	149
18,9	66	150,8
19,4	67	152,6
20,0	68	154,4
20,6	69	156,2
21,1	70	158
21,7	71	159,8
22,2	72	161,6
22,8	73	163,4
23,3	74	165,2
23,9	75	167
24,4	76	168,8
25,0	77	170,6
25,6	78	172,4
26,1	79	174,2
26,7	80	176
27,2	81	177,8
27,8	82	179,6
28,3	83	181,4
28,9	84	183,2
29,4	85	185
30,0	86	186,8
30,6	87	188,6
31,1	88	190,4
31,7	89	192,2
32,2	90	194
32,8	91	195,8
33,3	92	197,6
33,9	93	199,4
34,4	94	201,2

Temperature		
°C	CoU F	°F
35,0	95	203
35,6	96	204,8
36,1	97	206,6
36,7	98	208,4
37,2	99	210,2
37,8	100	212
38,3	101	213,8
38,9	102	215,6
39,4	103	217,4
40,0	104	219,2
40,6	105	221
41,1	106	222,8
41,7	107	224,6
42,2	108	226,4
42,8	109	228,2
43,3	110	230
43,9	111	231,8
44,4	112	233,6
45,0	113	235,4
45,6	114	237,2
46,1	115	239
46,7	116	240,8
47,2	117	242,6
47,8	118	244,4
48,3	119	246,2
48,9	120	248
49,4	121	249,8
50,0	122	251,6
50,6	123	253,4
51,1	124	255,2
51,7	125	257
52,2	126	258,8
52,8	127	260,6
53,3	128	262,4
53,9	129	264,2
54,4	130	266
55,0	131	267,8
55,6	132	269,6
56,1	133	271,4
56,7	134	273,2
57,2	135	275
57,8	136	276,8
58,3	137	278,6
58,9	138	280,4
59,4	139	282,2

Temperature		
°C	CoU F	°F
60,0	140	284
60,6	141	285,8
61,1	142	287,6
61,7	143	289,4
62,2	144	291,2
62,8	145	293
63,3	146	294,8
63,9	147	296,6
64,4	148	298,4
65,0	149	300,2
65,6	150	302
66,1	151	303,8
66,7	152	305,6
67,2	153	307,4
67,8	154	309,2
68,3	155	311
68,9	156	312,8
69,4	157	314,6
70,0	158	316,4
70,6	159	318,2
71,1	160	320
71,7	161	321,8
72,2	162	323,6
72,8	163	325,4
73,3	164	327,2
73,9	165	329
74,4	166	330,8
75,0	167	332,6
75,6	168	334,4
76,1	169	336,2
76,7	170	338
77,2	171	339,8
77,8	172	341,6
78,3	173	343,4
78,9	174	345,2
79,4	175	347
80,0	176	348,8
80,6	177	350,6
81,1	178	352,4
81,7	179	354,2
82,2	180	356
82,8	181	357,8
83,3	182	359,6
83,9	183	361,4
84,4	184	363,2



Trane optimizes the performance of homes and buildings around the world. A business of Ingersoll Rand, the leader in creating and sustaining safe, comfortable and energy efficient environments, Trane offers a broad portfolio of advanced controls and HVAC systems, comprehensive building services, and parts. For more information, visit www.trane.com.br

Trane has a policy of continuous product and product data improvement and reserves the right to change design and specifications without notice.

© 2016 Trane
All rights reserved
SSC-SVN008E-EN December 2016
Supersedes SSC-SVN008D-EN November 2015

Produced with paper that uses fewer trees and chemicals, less energy, and environmentally friendly print practices that reduce waste.

